



# STP25NM60N - STF25NM60N STB25NM60N/-1 - STW25NM60N

N-CHANNEL 600V 0.140Ω-20A TO-220/FP/D<sup>2</sup>/I<sup>2</sup>PAK/TO-247  
SECOND GENERATION MDmesh™ MOSFET

PRODUCT PREVIEW

**Table 1: General Features**

TYPE	V <sub>DS</sub> (@T <sub>jmax</sub> )	R <sub>DS(on)</sub>	I <sub>D</sub>
STB25NM60N-1	650 V	< 0.170 Ω	20 A
STF25NM60N	650 V	< 0.170 Ω	20(*) A
STP25NM60N	650 V	< 0.170 Ω	20 A
STW25NM60N	650 V	< 0.170 Ω	20 A
STB25NM60N	650 V	< 0.170 Ω	20 A

- WORLD'S LOWEST ON RESISTANCE
- TYPICAL R<sub>DS(on)</sub> = 0.140 Ω
- HIGH dv/dt AND AVALANCHE CAPABILITIES
- 100% AVALANCHE TESTED
- LOW INPUT CAPACITANCE AND GATE CHARGE
- LOW GATE INPUT RESISTANCE

## DESCRIPTION

The **STP25NM60N** is realized with the second generation of MDmesh Technology. This revolutionary MOSFET associates a new vertical structure to the Company's strip layout to yield the world's lowest on-resistance and gate charge. It is therefore suitable for the most demanding high efficiency converters

## APPLICATIONS

The MDmesh™ II family is very suitable for increase the power density of high voltage converters allowing system miniaturization and higher efficiencies.

**Table 2: Order Code**

SALES TYPE	MARKING	PACKAGE	PACKAGING
STB25NM60N-1	B25NM60N	I <sup>2</sup> PAK	TUBE
STF25NM60N	F25NM60N	TO-220FP	TUBE
STP25NM60N	P25NM60N	TO-220	TUBE
STW25NM60N	W25NM60N	TO-247	TUBE
STB25NM60N	B25NM60N	D <sup>2</sup> PAK	TAPE & REEL

**Figure 1: Package**

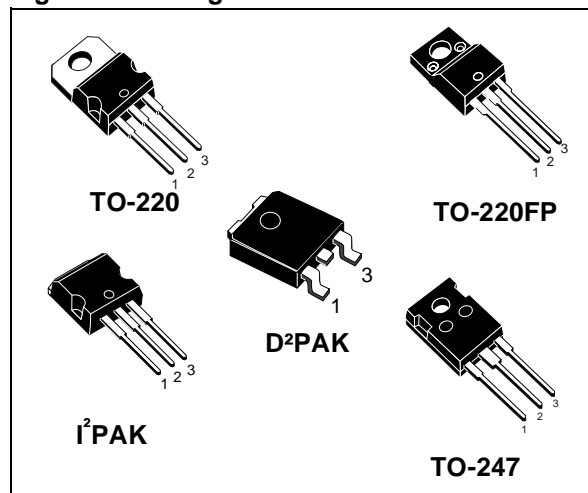

**Figure 2: Internal Schematic Diagram**

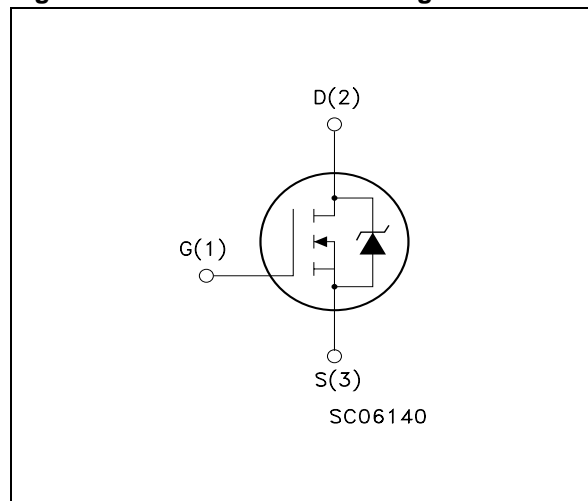

Rev. 4

**Table 3: Absolute Maximum ratings**

Symbol	Parameter	Value		Unit
		TO-220/I <sup>2</sup> PAK TO-247/D <sup>2</sup> PAK	TO-220FP	
V <sub>DS</sub>	Drain-source Voltage (V <sub>GS</sub> = 0)	600		V
V <sub>DGR</sub>	Drain-gate Voltage (R <sub>GS</sub> = 20 kΩ)	600		V
V <sub>GS</sub>	Gate- source Voltage	± 25		V
I <sub>D</sub>	Drain Current (continuous) at T <sub>C</sub> = 25°C	20	20 (*)	A
I <sub>D</sub>	Drain Current (continuous) at T <sub>C</sub> = 100°C	12.8	12.8 (*)	A
I <sub>DM</sub> (1)	Drain Current (pulsed)	80	80 (*)	A
P <sub>TOT</sub>	Total Dissipation at T <sub>C</sub> = 25°C	160	40	W
	Derating Factor	1.28	0.32	W/°C
dv/dt (2)	Peak Diode Recovery voltage slope	TBD		V/ns
T <sub>stg</sub>	Storage Temperature	- 55 to 150		°C
T <sub>j</sub>	Max. Operating Junction Temperature	150		°C

(\*) Limited only by maximum temperature allowed

(1) Pulse width limited by safe operating area

(2) I<sub>SD</sub> ≤ 20 A, di/dt ≤ 400 A/μs, V<sub>DD</sub> = 80%V<sub>(BR)DSS</sub>.

**Table 4: Thermal Data**

		TO-220/I <sup>2</sup> PAK TO-247/D <sup>2</sup> PAK	TO-220FP	
R <sub>thj-case</sub>	Thermal Resistance Junction-case Max	0.78	3.1	°C/W
R <sub>thj-amb</sub>	Thermal Resistance Junction-ambient Max	62.5		°C/W
T <sub>l</sub>	Maximum Lead Temperature For Soldering Purpose	300		°C

**Table 5: Avalanche Characteristics**

Symbol	Parameter	Max Value	Unit
I <sub>AS</sub>	Avalanche Current, Repetitive or Not-Repetitive (pulse width limited by T <sub>j</sub> max)	TBD	A
E <sub>AS</sub>	Single Pulse Avalanche Energy (starting T <sub>j</sub> = 25 °C, I <sub>D</sub> = I <sub>AS</sub> , V <sub>DD</sub> = 50 V)	TBD	mJ

**ELECTRICAL CHARACTERISTICS (T<sub>CASE</sub> =25°C UNLESS OTHERWISE SPECIFIED)**

**Table 6: On /Off**

Symbol	Parameter	Test Conditions	Value			Unit
			Min.	Typ.	Max.	
V <sub>(BR)DSS</sub>	Drain-source Breakdown Voltage	I <sub>D</sub> = 1 mA, V <sub>GS</sub> = 0	600			V
dv/dt(2)	Drain Source Voltage Slope	V <sub>dd</sub> =TBD, I <sub>d</sub> =TBD, V <sub>gs</sub> =TBD	TBD			V/ns
I <sub>DSS</sub>	Zero Gate Voltage Drain Current (V <sub>GS</sub> = 0)	V <sub>DS</sub> = Max Rating V <sub>DS</sub> = Max Rating, T <sub>C</sub> = 125°C			1 10	μA μA
I <sub>GSS</sub>	Gate-body Leakage Current (V <sub>DS</sub> = 0)	V <sub>GS</sub> = ± 20 V			100	nA
V <sub>GS(th)</sub>	Gate Threshold Voltage	V <sub>DS</sub> = V <sub>GS</sub> , I <sub>D</sub> = 250 μA	2	3	4	V
R <sub>DS(on)</sub>	Static Drain-source On Resistance	V <sub>GS</sub> = 10 V, I <sub>D</sub> = 10 A		0.140	0.170	Ω

(2) Characteristic value at turn off on inductive load

**ELECTRICAL CHARACTERISTICS (CONTINUED)**

**Table 7: Dynamic**

Symbol	Parameter	Test Conditions	Min.	Typ.	Max.	Unit
$g_{fs}$ (1)	Forward Transconductance	$V_{DS} = 15V$ , $I_D = 10A$		17		S
$C_{iss}$ $C_{oss}$ $C_{rss}$	Input Capacitance Output Capacitance Reverse Transfer Capacitance	$V_{DS} = 25V$ , $f = 1MHz$ , $V_{GS} = 0$		2565 511 77		pF pF pF
$C_{OSS\ eq}$ (3).	Equivalent Output Capacitance	$V_{GS} = 0V$ , $V_{DS} = 0$ to 480 V		TBD		pF
$R_G$	Gate Input Resistance	$f=1MHz$ Gate DC Bias = 0 Test Signal Level = 20mV Open Drain		2		$\Omega$
$t_{d(on)}$ $t_r$ $t_{d(off)}$ $t_f$	Turn-on Delay Time Rise Time Turn-off-Delay Time Fall Time	$V_{DD} = 300V$ , $I_D = 10A$ , $R_G = 4.7\Omega$ , $V_{GS} = 10V$ (see Figure 4)		TBD TBD TBD TBD		ns ns ns ns
$Q_g$ $Q_{gs}$ $Q_{gd}$	Total Gate Charge Gate-Source Charge Gate-Drain Charge	$V_{DD} = 480V$ , $I_D = 20A$ , $V_{GS} = 10V$ (see Figure 7)		93 TBD TBD		nC nC nC

**Table 8: Source Drain Diode**

Symbol	Parameter	Test Conditions	Min.	Typ.	Max.	Unit
$I_{SD}$ $I_{SDM}$ (2)	Source-drain Current Source-drain Current (pulsed)				20 80	A A
$V_{SD}$ (1)	Forward On Voltage	$I_{SD} = 20A$ , $V_{GS} = 0$			1.3	V
$t_{rr}$ $Q_{rr}$ $I_{RRM}$	Reverse Recovery Time Reverse Recovery Charge Reverse Recovery Current	$I_{SD} = 25A$ , $di/dt = 100A/\mu s$ $V_{DD} = 100V$ (see Figure 5)		TBD TBD TBD		ns $\mu C$ A
$t_{rr}$ $Q_{rr}$ $I_{RRM}$	Reverse Recovery Time Reverse Recovery Charge Reverse Recovery Current	$I_{SD} = 25A$ , $di/dt = 100A/\mu s$ $V_{DD} = 100V$ , $T_j = 150^\circ C$ (see Figure 5)		TBD TBD TBD		ns $\mu C$ A

(1) Pulsed: Pulse duration = 300  $\mu s$ , duty cycle 1.5 %.

(2) Pulse width limited by safe operating area.

(3)  $C_{OSS\ eq}$  is defined as a constant equivalent capacitance giving the same charging time as  $C_{OSS}$  when  $V_{DS}$  increases from 0 to 80%  $V_{DSS}$ .

Figure 3: Unclamped Inductive Load Test Circuit

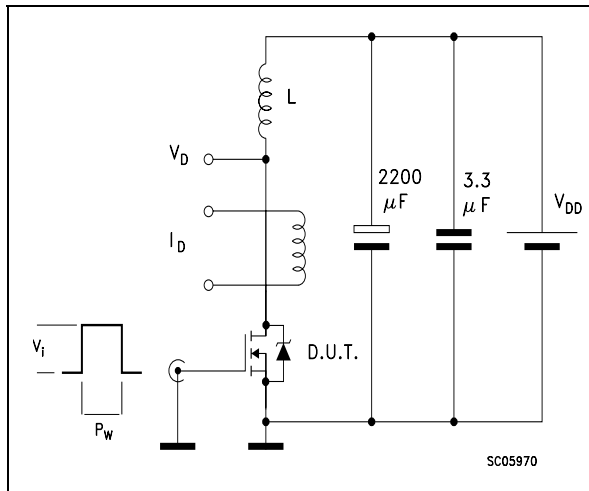

Figure 4: Switching Times Test Circuit For Resistive Load

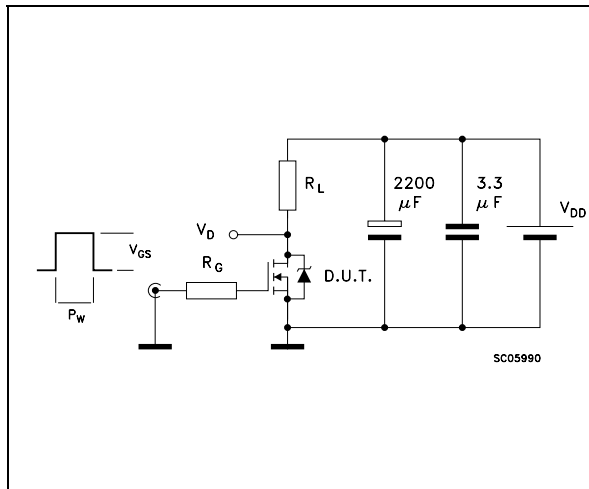

Figure 5: Test Circuit For Inductive Load Switching and Diode Recovery Times

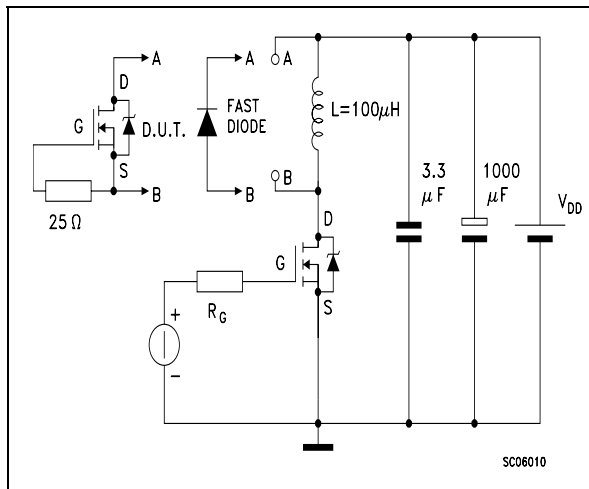

Figure 6: Unclamped Inductive Wafeform

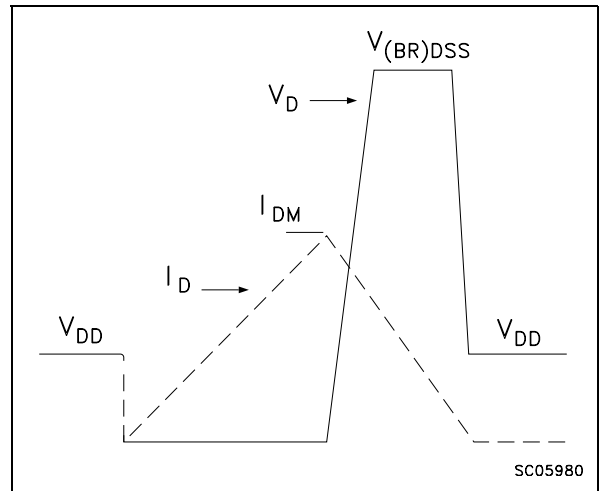
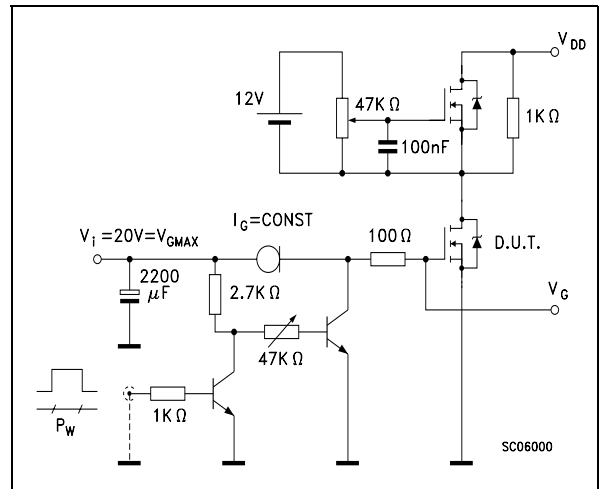
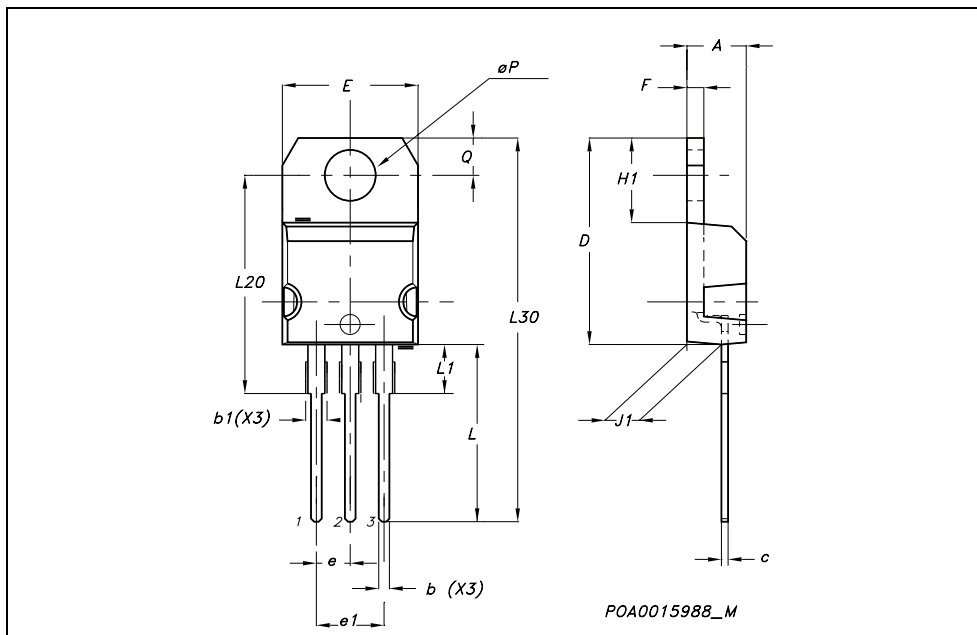

Figure 7: Gate Charge Test Circuit



TO-220 MECHANICAL DATA

DIM.	mm.			inch		
	MIN.	TYP.	MAX.	MIN.	TYP.	MAX.
A	4.40		4.60	0.173		0.181
b	0.61		0.88	0.024		0.034
b1	1.15		1.70	0.045		0.066
c	0.49		0.70	0.019		0.027
D	15.25		15.75	0.60		0.620
E	10		10.40	0.393		0.409
e	2.40		2.70	0.094		0.106
e1	4.95		5.15	0.194		0.202
F	1.23		1.32	0.048		0.052
H1	6.20		6.60	0.244		0.256
J1	2.40		2.72	0.094		0.107
L	13		14	0.511		0.551
L1	3.50		3.93	0.137		0.154
L20		16.40			0.645	
L30		28.90			1.137	
øP	3.75		3.85	0.147		0.151
Q	2.65		2.95	0.104		0.116



TO-220FP MECHANICAL DATA

DIM.	mm.			inch		
	MIN.	TYP.	MAX.	MIN.	TYP.	MAX.
A	4.4		4.6	0.173		0.181
B	2.5		2.7	0.098		0.106
D	2.5		2.75	0.098		0.108
E	0.45		0.7	0.017		0.027
F	0.75		1	0.030		0.039
F1	1.15		1.7	0.045		0.067
F2	1.15		1.7	0.045		0.067
G	4.95		5.2	0.195		0.204
G1	2.4		2.7	0.094		0.106
H	10		10.4	0.393		0.409
L2		16			0.630	
L3	28.6		30.6	1.126		1.204
L4	9.8		10.6	.0385		0.417
L5	2.9		3.6	0.114		0.141
L6	15.9		16.4	0.626		0.645
L7	9		9.3	0.354		0.366
Ø	3		3.2	0.118		0.126

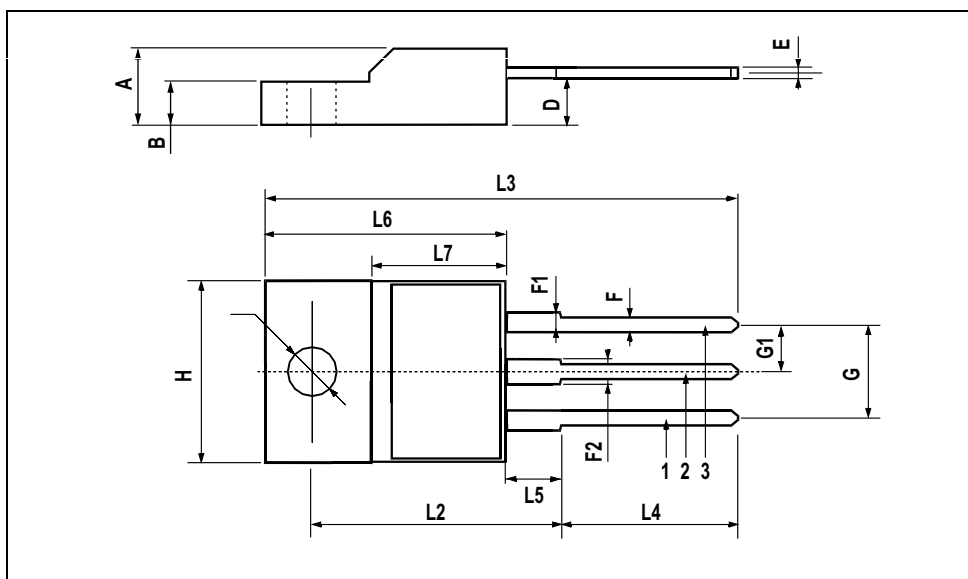

TO-262 (I<sup>2</sup>PAK) MECHANICAL DATA

DIM.	mm.			inch		
	MIN.	TYP.	MAX.	MIN.	TYP.	MAX.
A	4.40		4.60	0.173		0.181
A1	2.40		2.72	0.094		0.107
b	0.61		0.88	0.024		0.034
b1	1.14		1.70	0.044		0.066
c	0.49		0.70	0.019		0.027
c2	1.23		1.32	0.048		0.052
D	8.95		9.35	0.352		0.368
e	2.40		2.70	0.094		0.106
e1	4.95		5.15	0.194		0.202
E	10		10.40	0.393		0.410
L	13		14	0.511		0.551
L1	3.50		3.93	0.137		0.154
L2	1.27		1.40	0.050		0.055

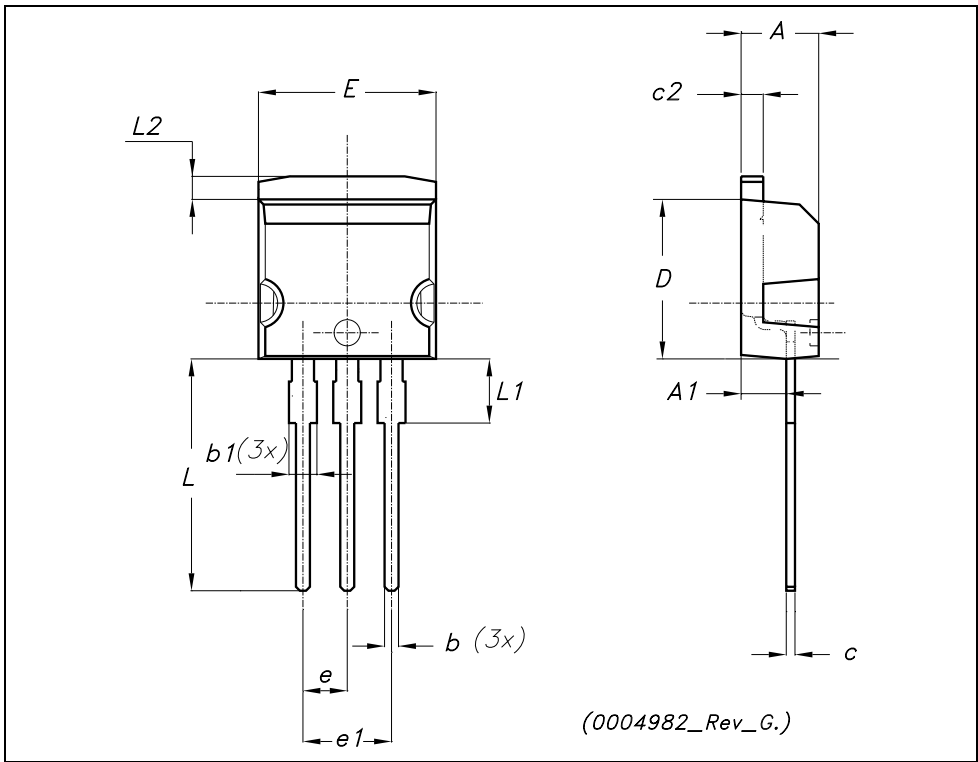

TO-247 MECHANICAL DATA

DIM.	mm.			inch		
	MIN.	TYP.	MAX.	MIN.	TYP.	MAX.
A	4.85		5.15	0.19		0.20
A1	2.20		2.60	0.086		0.102
b	1.0		1.40	0.039		0.055
b1	2.0		2.40	0.079		0.094
b2	3.0		3.40	0.118		0.134
c	0.40		0.80	0.015		0.03
D	19.85		20.15	0.781		0.793
E	15.45		15.75	0.608		0.620
e		5.45			0.214	
L	14.20		14.80	0.560		0.582
L1	3.70		4.30	0.14		0.17
L2		18.50			0.728	
øP	3.55		3.65	0.140		0.143
øR	4.50		5.50	0.177		0.216
S		5.50			0.216	

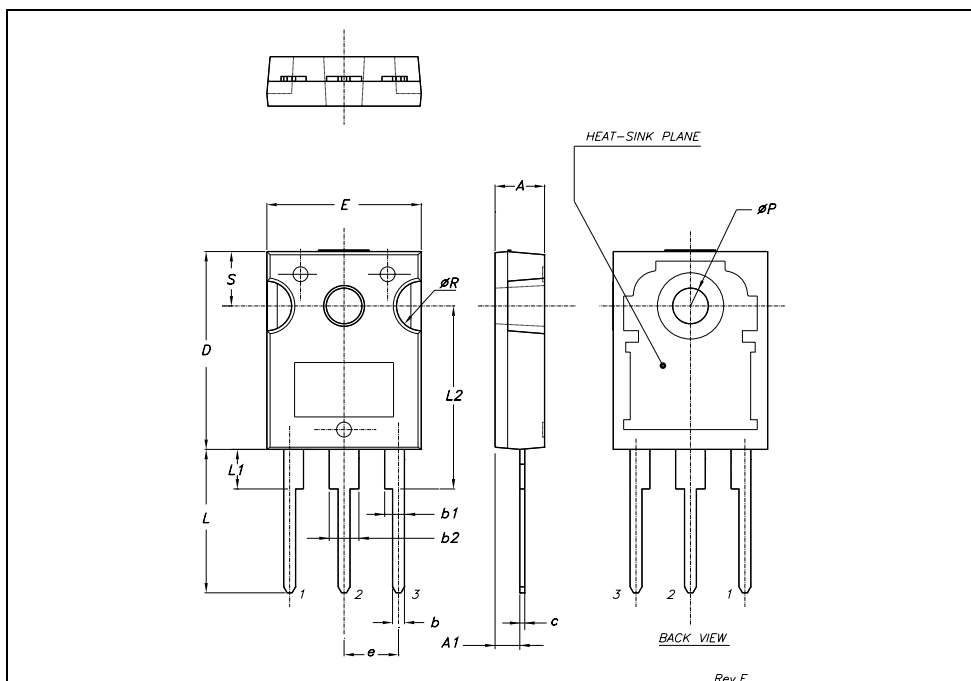

TO-252 (DPAK) MECHANICAL DATA

DIM.	mm			inch		
	MIN.	TYP.	MAX.	MIN.	TYP.	MAX.
A	2.20		2.40	0.087		0.094
A1	0.90		1.10	0.035		0.043
A2	0.03		0.23	0.001		0.009
B	0.64		0.90	0.025		0.035
B2	5.20		5.40	0.204		0.213
C	0.45		0.60	0.018		0.024
C2	0.48		0.60	0.019		0.024
D	6.00		6.20	0.236		0.244
E	6.40		6.60	0.252		0.260
G	4.40		4.60	0.173		0.181
H	9.35		10.10	0.368		0.398
L2		0.8			0.031	
L4	0.60		1.00	0.024		0.039
V2	0°		8°	0°		0°

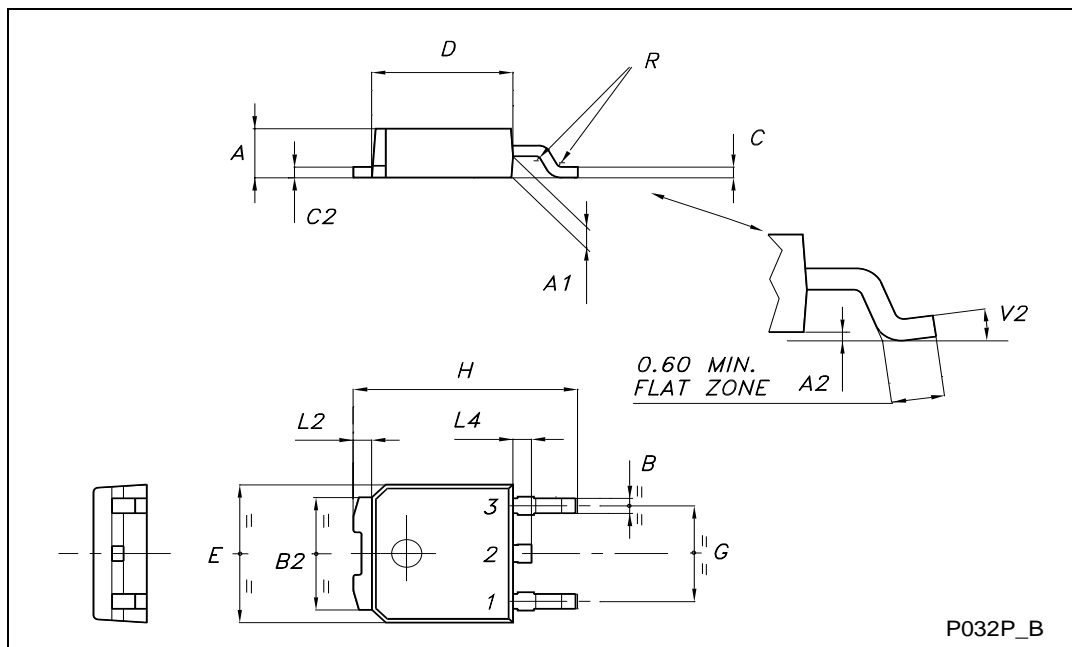

P032P\_B

**D<sup>2</sup>PAK FOOTPRINT**

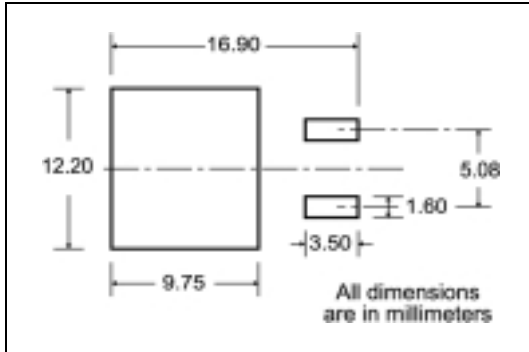

**TAPE AND REEL SHIPMENT**

**TAPE MECHANICAL DATA**

DIM.	mm		inch	
	MIN.	MAX.	MIN.	MAX.
A0	10.5	10.7	0.413	0.421
B0	15.7	15.9	0.618	0.626
D	1.5	1.6	0.059	0.063
D1	1.59	1.61	0.062	0.063
E	1.65	1.85	0.065	0.073
F	11.4	11.6	0.449	0.456
K0	4.8	5.0	0.189	0.197
P0	3.9	4.1	0.153	0.161
P1	11.9	12.1	0.468	0.476
P2	1.9	2.1	0.075	0.082
R	50		1.574	
T	0.25	0.35	0.0098	0.0137
W	23.7	24.3	0.933	0.956

**REEL MECHANICAL DATA**

DIM.	mm		inch	
	MIN.	MAX.	MIN.	MAX.
A		330		12.992
B	1.5		0.059	
C	12.8	13.2	0.504	0.520
D	20.2		0.795	
G	24.4	26.4	0.960	1.039
N	100		3.937	
T		30.4		1.197

BASE QTY	BULK QTY
1000	1000

\* on sales type

**Table 9: Revision History**

<b>Date</b>	<b>Revision</b>	<b>Description of Changes</b>
30-Nov-2004	1	First Release.
22-Mar-2005	2	Modified title
23-May-2005	3	Inserted some values in Tab7
08-Jun-2005	4	Inserted new row in table 6

Information furnished is believed to be accurate and reliable. However, STMicroelectronics assumes no responsibility for the consequences of use of such information nor for any infringement of patents or other rights of third parties which may result from its use. No license is granted by implication or otherwise under any patent or patent rights of STMicroelectronics. Specifications mentioned in this publication are subject to change without notice. This publication supersedes and replaces all information previously supplied. STMicroelectronics products are not authorized for use as critical components in life support devices or systems without express written approval of STMicroelectronics.

The ST logo is a registered trademark of STMicroelectronics

All other names are the property of their respective owners

© 2005 STMicroelectronics - All Rights Reserved

STMicroelectronics group of companies

Australia - Belgium - Brazil - Canada - China - Czech Republic - Finland - France - Germany - Hong Kong - India - Israel - Italy - Japan - Malaysia - Malta - Morocco - Singapore - Spain - Sweden - Switzerland - United Kingdom - United States of America