

**SILICON NPN SWITCHING TRANSISTOR**

• SGS-THOMSON PREFERRED SALESTYPE

**DESCRIPTION**

The MJE13009 is a multi-epitaxial mesa NPN transistor. It is mounted in Jedec TO-220 plastic package, intended for use in motor controls, switching regulators, deflection circuits, etc.

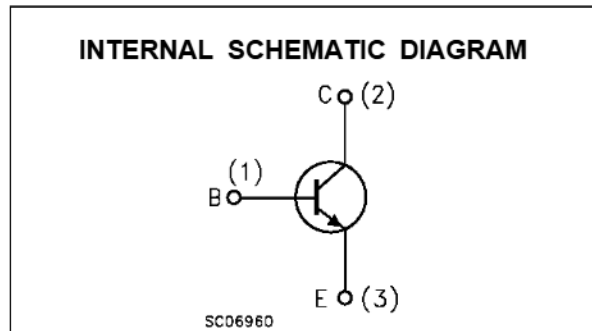
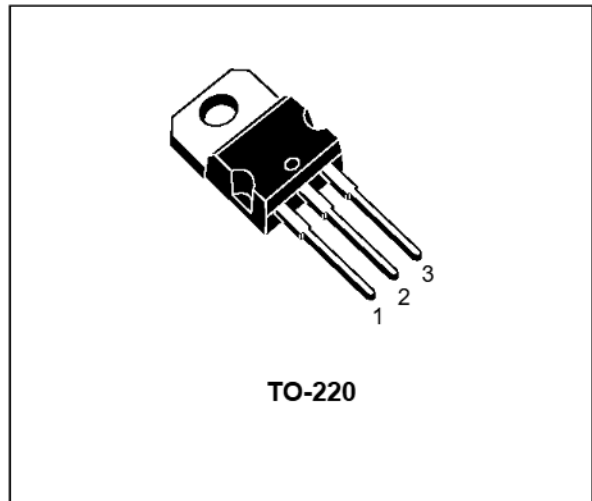

**ABSOLUTE MAXIMUM RATINGS**

Symbol	Parameter	Value	Unit
$V_{CE0}$	Collector-Emitter Voltage ( $I_B = 0$ )	400	V
$V_{CEV}$	Collector-Emitter Voltage ( $V_{BE} = -1.5$ V)	700	V
$V_{EBO}$	Emitter-Base Voltage ( $I_C = 0$ )	9	V
$I_C$	Collector Current	12	A
$I_{CM}$	Collector Peak Current ( $t_p \leq 10$ ms)	24	A
$I_B$	Base Current	6	A
$I_{BM}$	Base Peak Current ( $t_p \leq 10$ ms)	12	A
$I_E$	Emitter Current	18	A
$I_{EM}$	Emitter Peak Current	36	A
$P_{tot}$	Total Power Dissipation at $T_c \leq 25$ °C	100	W
$T_{stg}$	Storage Temperature	-65 to 150	°C
$T_j$	Max. Operating Junction Temperature	150	°C

**THERMAL DATA**

R <sub>thj-case</sub>	Thermal Resistance Junction-case	Max	1.25	°C/W
-----------------------	----------------------------------	-----	------	------

**ELECTRICAL CHARACTERISTICS** (T<sub>case</sub> = 25 °C unless otherwise specified)

Symbol	Parameter	Test Conditions	Min.	Typ.	Max.	Unit
I <sub>CEV</sub>	Collector Cut-off Current	V <sub>CEV</sub> = rated value V <sub>BE(off)</sub> = 1.5 V V <sub>CEV</sub> = rated value V <sub>EB(off)</sub> = 1.5 V T <sub>case</sub> = 100°C			1	mA
I <sub>EBO</sub>	Emitter Cut-off Current (I <sub>C</sub> = 0)	V <sub>EB</sub> = 9 V			1	mA
V <sub>CE0(sus)*</sub>	Collector-Emitter Sustaining Voltage	I <sub>C</sub> = 10 mA      I <sub>E</sub> = 0	400			V
V <sub>CE(sat)*</sub>	Collector-Emitter Saturation Voltage	I <sub>C</sub> = 5 A      I <sub>B</sub> = 1 A I <sub>C</sub> = 8 A      I <sub>B</sub> = 1.6 A I <sub>C</sub> = 12 A      I <sub>B</sub> = 3 A I <sub>C</sub> = 8 A      I <sub>B</sub> = 1.6 A T <sub>case</sub> = 100°C			1 1.5 3 2	V V V V
V <sub>BE(sat)*</sub>	Base-Emitter Saturation Voltage	I <sub>C</sub> = 5 A      I <sub>B</sub> = 1 A I <sub>C</sub> = 8 A      I <sub>B</sub> = 1.6 A I <sub>C</sub> = 8 A      I <sub>B</sub> = 1.6 A T <sub>case</sub> = 100°C			1.2 1.6 1.5	V V V
h <sub>FE</sub> *	DC Current Gain	I <sub>C</sub> = 5 A      V <sub>CE</sub> = 5 V I <sub>C</sub> = 8 A      V <sub>CE</sub> = 5 V	8 6		40 30	
f <sub>T</sub>	Transistor Frequency	I <sub>C</sub> = 500 mA      V <sub>CE</sub> = 10 V	4			MHz
C <sub>OB</sub>	Output Capacitance	V <sub>CB</sub> = 10 A      I <sub>E</sub> = 0 f = 0.1 MHz		180		pF
t <sub>on</sub> t <sub>s</sub> t <sub>f</sub>	Turn-on Time Storage Time Fall Time	<b>RESISTIVE LOAD</b> V <sub>CC</sub> = 125 V      I <sub>C</sub> = 8 A I <sub>B1</sub> = -I <sub>B2</sub> = 1.6 A      t <sub>p</sub> = 25 ∞s Duty Cycle ≤ 1%			1.1 3 0.7	∞s ∞s ∞s

\* Pulsed: Pulse duration = 300∞s, duty cycle ≤ 2 %

**Safe Operating Areas**

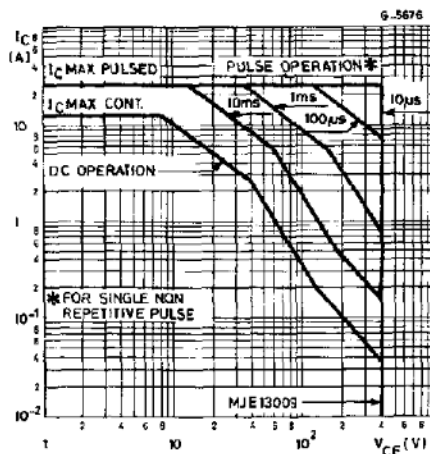

**Derating Curve**

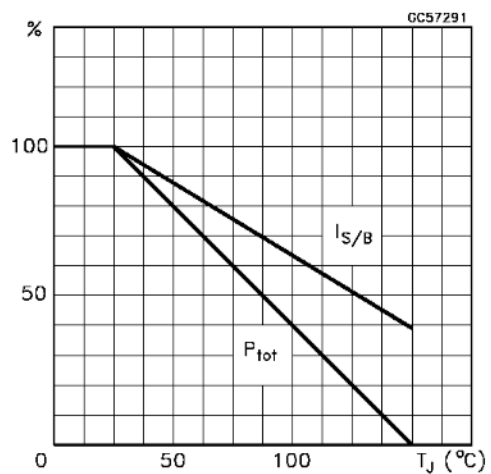

DC Current Gain

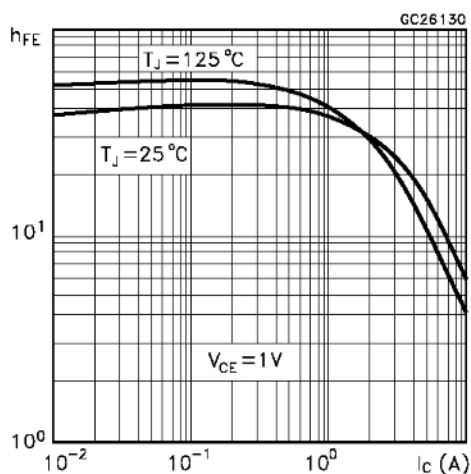

DC Current Gain

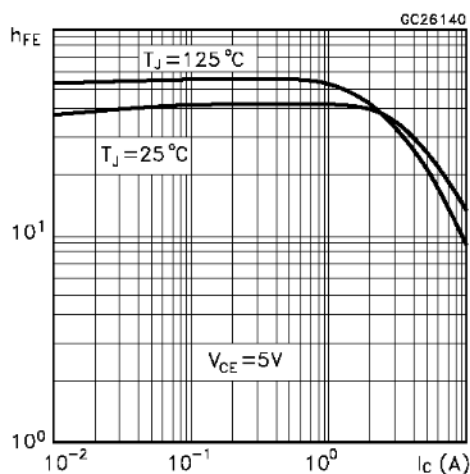

Collector Emitter Saturation Voltage

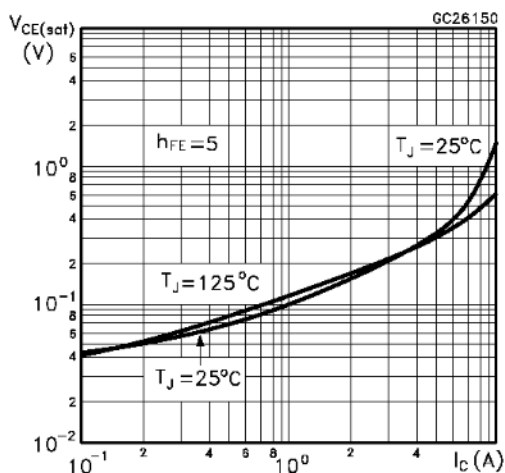

Base Emitter Saturation Voltage

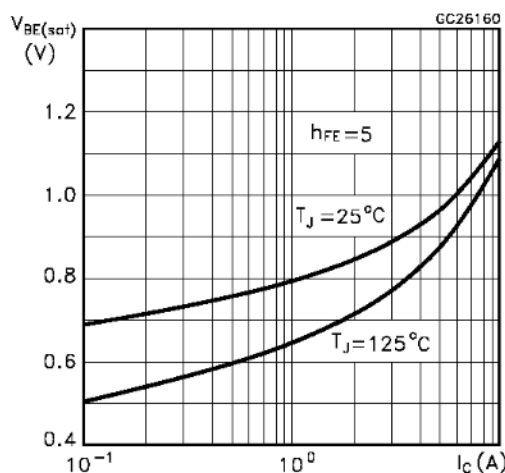

Inductive Fall Time

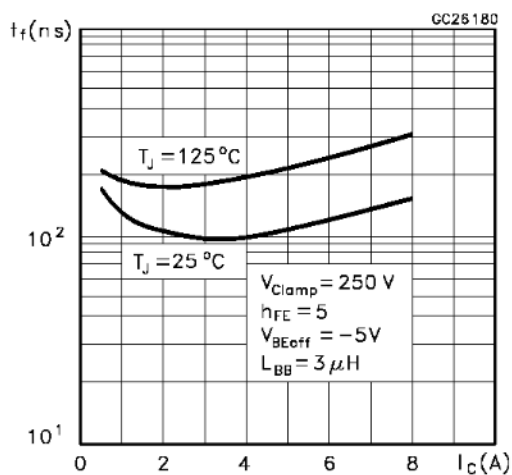

Inductive Storage Time

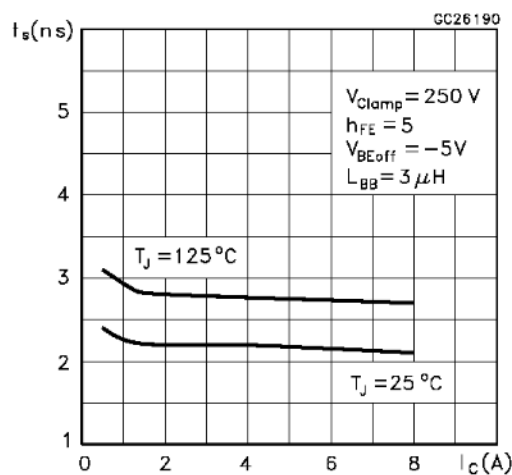

Reverse Biased SOA

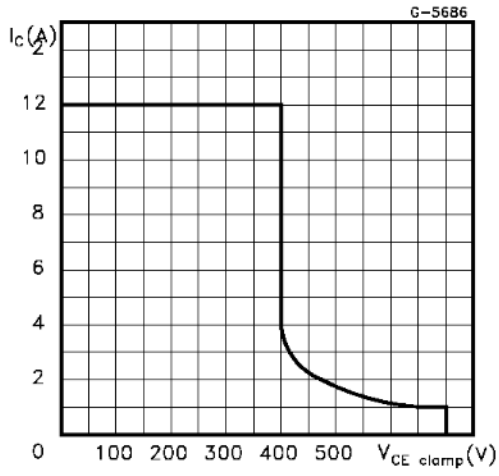

RBSOA and Inductive Load Switching Test Circuit

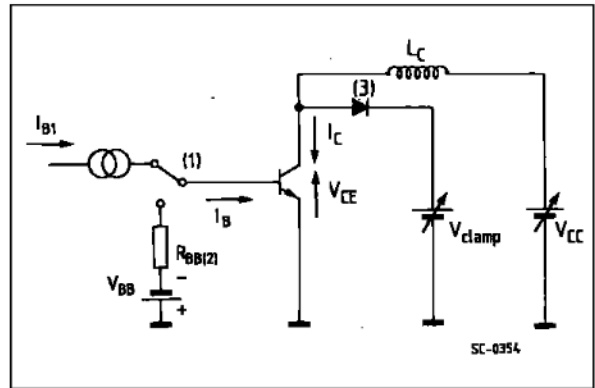

- (1) Fast electronic switch
- (2) Non-inductive Resistor
- (3) Fast recovery rectifier

## TO-220 MECHANICAL DATA

DIM.	mm			inch		
	MIN.	TYP.	MAX.	MIN.	TYP.	MAX.
A	4.40		4.60	0.173		0.181
C	1.23		1.32	0.048		0.051
D	2.40		2.72	0.094		0.107
D1		1.27			0.050	
E	0.49		0.70	0.019		0.027
F	0.61		0.88	0.024		0.034
F1	1.14		1.70	0.044		0.067
F2	1.14		1.70	0.044		0.067
G	4.95		5.15	0.194		0.203
G1	2.4		2.7	0.094		0.106
H2	10.0		10.40	0.393		0.409
L2		16.4			0.645	
L4	13.0		14.0	0.511		0.551
L5	2.65		2.95	0.104		0.116
L6	15.25		15.75	0.600		0.620
L7	6.2		6.6	0.244		0.260
L9	3.5		3.93	0.137		0.154
DIA.	3.75		3.85	0.147		0.151

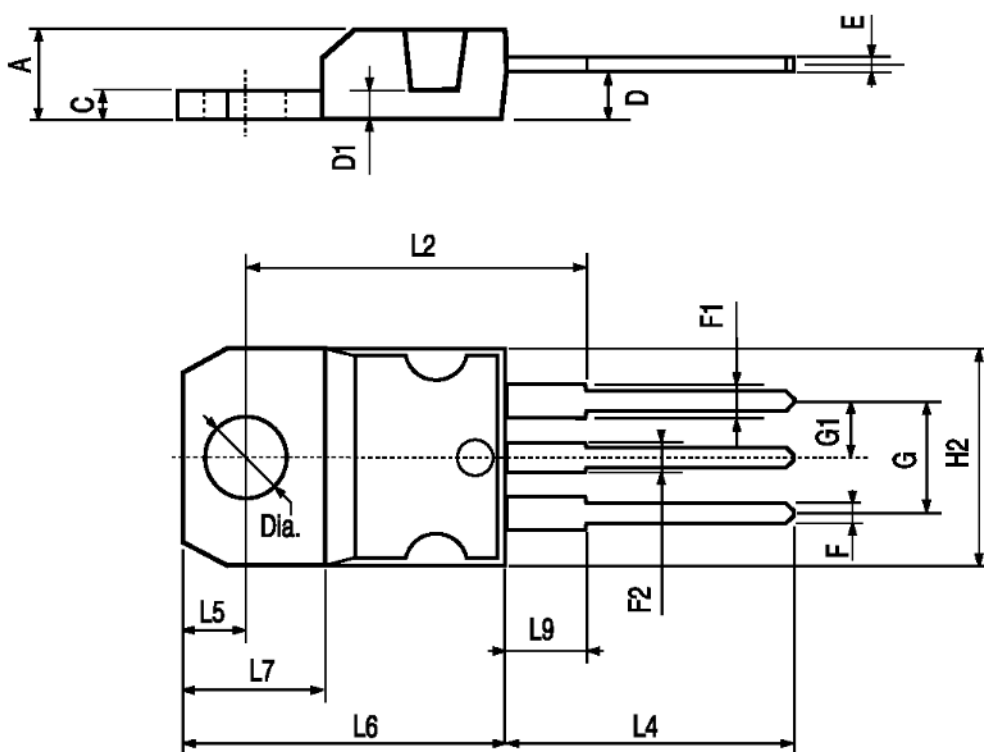

P011C

Information furnished is believed to be accurate and reliable. However, SGS-THOMSON Microelectronics assumes no responsibility for the consequences of use of such information nor for any infringement of patents or other rights of third parties which may result from its use. No license is granted by implication or otherwise under any patent or patent rights of SGS-THOMSON Microelectronics. Specifications mentioned in this publication are subject to change without notice. This publication supersedes and replaces all information previously supplied. SGS-THOMSON Microelectronics products are not authorized for use as critical components in life support devices or systems without express written approval of SGS-THOMSON Microelectronics.

♥ 1997 SGS-THOMSON Microelectronics - Printed in Italy - All Rights Reserved

SGS-THOMSON Microelectronics GROUP OF COMPANIES  
Australia - Brazil - Canada - China - France - Germany - Hong Kong - Italy - Japan - Korea - Malaysia - Malta - Morocco - The Netherlands -  
Singapore - Spain - Sweden - Switzerland - Taiwan - Thailand - United Kingdom - U.S.A