

## N-Channel Enhancement Mode MOSFET

### Features

- 125V/190A  
 $R_{DS(ON)} = 6.3 \text{ m}\Omega \text{ (typ.) @ } V_{GS}=10\text{V}$
- 100% avalanche tested
- Reliable and Rugged
- Lead Free and Green Devices Available (RoHS Compliant)

### Pin Description

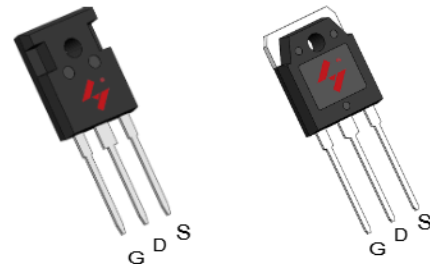

TO-247A-3L

TO-3P-3L

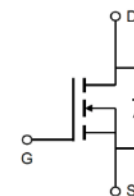

### Applications

- Switching application
- Power Management for Inverter Systems.



N Channel MOSFET

### Ordering and Marking Information

 <b>W</b> <b>HY3912</b> YYXXXJWW G	 <b>A</b> <b>HY3912</b> YYXXXJWW G	Package Code W : TO-247A-3L      A : TO-3P-3L  Date Code YYXXX WW              Assembly Material G : Lead Free Device
--	--	--

Note: HUAYI lead-free products contain molding compounds/die attach materials and 100% matte tin plate Termination finish; which are fully compliant with RoHS. HUAYI lead-free products meet or exceed the lead-free requirements of IPC/JEDEC J-STD-020 for MSL classification at lead-free peak reflow temperature. HUAYI defines "Green" to mean lead-free (RoHS compliant) and halogen free (Br or Cl does not exceed 900ppm by weight in homogeneous material and total of Br and Cl does not exceed 1500ppm by weight).

HUAYI reserves the right to make changes, corrections, enhancements, modifications, and improvements to this product and/or to this document at any time without notice.

## Absolute Maximum Ratings

Symbol	Parameter	Rating	Unit
<b>Common Ratings</b> ( $T_C=25^\circ\text{C}$ Unless Otherwise Noted)			
$V_{DSS}$	Drain-Source Voltage	125	V
$V_{GSS}$	Gate-Source Voltage	$\pm 25$	
$T_J$	Maximum Junction Temperature	175	$^\circ\text{C}$
$T_{STG}$	Storage Temperature Range	-55 to 175	$^\circ\text{C}$
$I_S$	Diode Continuous Forward Current	$T_C=25^\circ\text{C}$ 190	A
<b>Mounted on Large Heat Sink</b>			
$I_{DM}$	Pulsed Drain Current *	$T_C=25^\circ\text{C}$ 585**	A
$I_D$	Continuous Drain Current	$T_C=25^\circ\text{C}$ 190	A
		$T_C=100^\circ\text{C}$ 128	
$P_D$	Maximum Power Dissipation	$T_C=25^\circ\text{C}$ 349	W
		$T_C=100^\circ\text{C}$ 174	
$R_{\theta JC}$	Thermal Resistance-Junction to Case	0.43	$^\circ\text{C/W}$
$R_{\theta JA}$	Thermal Resistance-Junction to Ambient	62.5	
<b>Avalanche Ratings</b>			
$E_{AS}$	Avalanche Energy, Single Pulsed	$L=0.5\text{mH}$ 1200***	mJ

Note : \* Repetitive rating ; pulse width limited by junction temperature

\*\* Drain current is limited by junction temperature

\*\*\*  $V_D=100\text{V}$

## Electrical Characteristics ( $T_C = 25^\circ\text{C}$ Unless Otherwise Noted)

Symbol	Parameter	Test Conditions	HY3912			Unit
			Min.	Typ.	Max.	
<b>Static Characteristics</b>						
$BV_{DSS}$	Drain-Source Breakdown Voltage	$V_{GS}=0\text{V}, I_{DS}=250\mu\text{A}$	125	-	-	V
$I_{DSS}$	Zero Gate Voltage Drain Current	$V_{DS}=125\text{V}, V_{GS}=0\text{V}$ $T_J=85^\circ\text{C}$	-	-	1	$\mu\text{A}$
			-	-	10	
$V_{GS(th)}$	Gate Threshold Voltage	$V_{DS}=V_{GS}, I_{DS}=250\mu\text{A}$	2.0	3.0	4.0	V
$I_{GSS}$	Gate Leakage Current	$V_{GS}=\pm 25\text{V}, V_{DS}=0\text{V}$	-	-	$\pm 100$	nA
$R_{DS(ON)}^*$	Drain-Source On-state Resistance	$V_{GS}=10\text{V}, I_{DS}=85\text{A}$	-	6.3	7.5	$\text{m}\Omega$
<b>Diode Characteristics</b>						
$V_{SD}^*$	Diode Forward Voltage	$I_{SD}=85\text{A}, V_{GS}=0\text{V}$	-	0.8	1	V
$t_{rr}$	Reverse Recovery Time	$I_{SD}=85\text{A}, dI_{SD}/dt=100\text{A}/\mu\text{s}$	-	70	-	ns
$Q_{rr}$	Reverse Recovery Charge		-	110	-	nC

## Electrical Characteristics (Cont.) (T<sub>C</sub> = 25°C Unless Otherwise Noted)

Symbol	Parameter	Test Conditions	HY3912			Unit
			Min.	Typ.	Max.	
<b>Dynamic Characteristics</b>						
R <sub>G</sub>	Gate Resistance	V <sub>GS</sub> =0V, V <sub>DS</sub> =0V, F=1MHz	-	1.1	-	Ω
C <sub>iss</sub>	Input Capacitance	V <sub>GS</sub> =0V, V <sub>DS</sub> =25V, Frequency=1.0MHz	-	7348	-	pF
C <sub>oss</sub>	Output Capacitance		-	750	-	
C <sub>rss</sub>	Reverse Transfer Capacitance		-	465	-	
t <sub>d(ON)</sub>	Turn-on Delay Time	V <sub>DD</sub> =62.5 V, R <sub>G</sub> = 6 Ω, I <sub>DS</sub> =85A, V <sub>GS</sub> =10V,	-	35	-	ns
T <sub>r</sub>	Turn-on Rise Time		-	46	-	
t <sub>d(OFF)</sub>	Turn-off Delay Time		-	92	-	
T <sub>f</sub>	Turn-off Fall Time		-	52	-	
<b>Gate Charge Characteristics</b>						
Q <sub>g</sub>	Total Gate Charge	V <sub>DS</sub> =100V, V <sub>GS</sub> =10V, I <sub>DS</sub> =85A	-	185	-	nC
Q <sub>gs</sub>	Gate-Source Charge		-	28	-	
Q <sub>gd</sub>	Gate-Drain Charge		-	64	-	

Note \* : Pulse test ; pulse width ≤300μs, duty cycle ≤2%.

## Typical Operating Characteristics

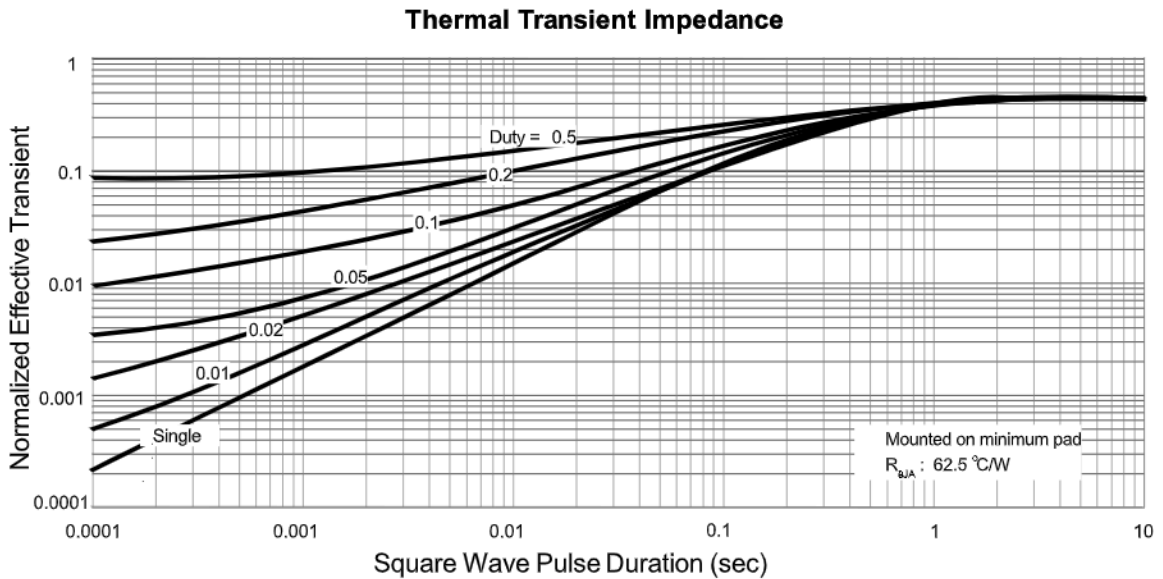
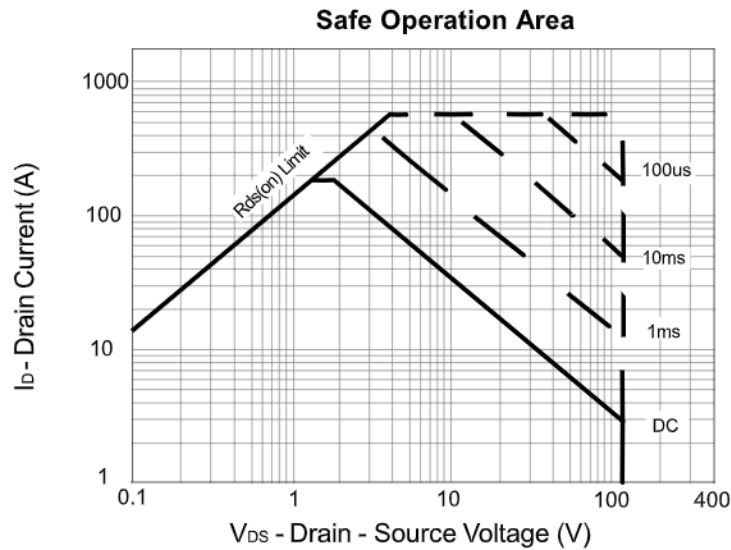
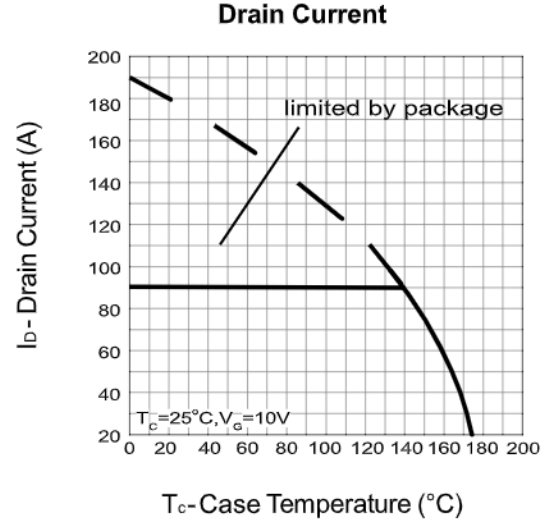
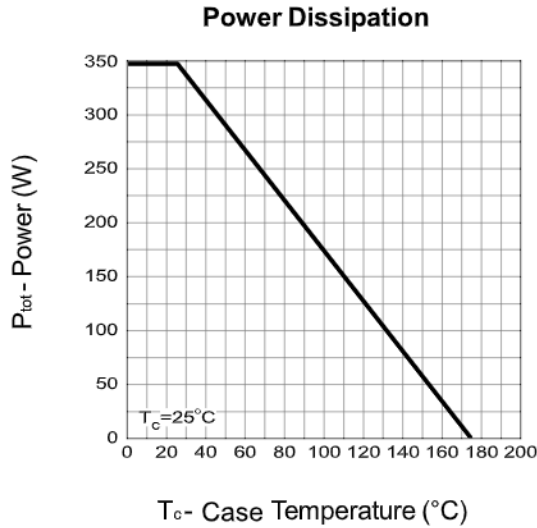

**Typical Operating Characteristics (Cont.)**

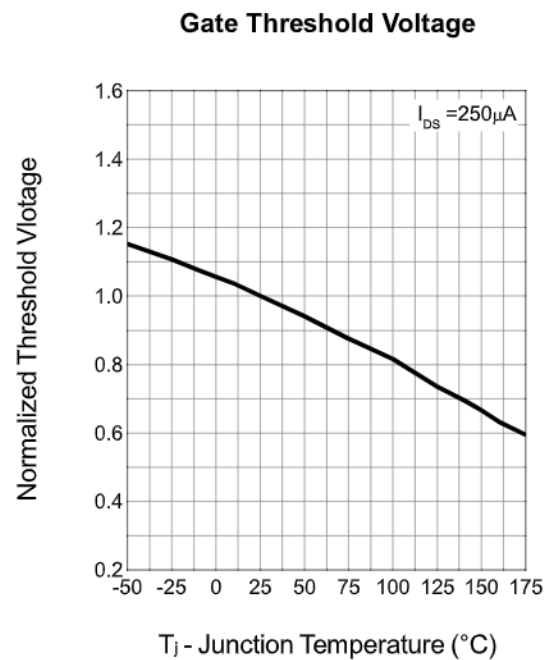
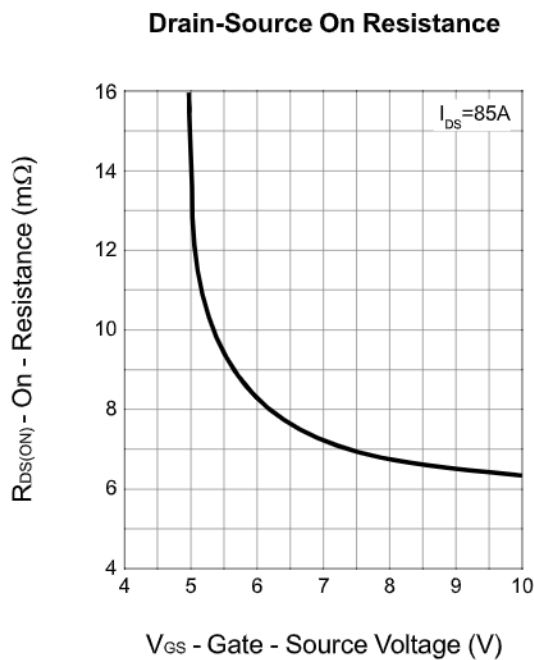
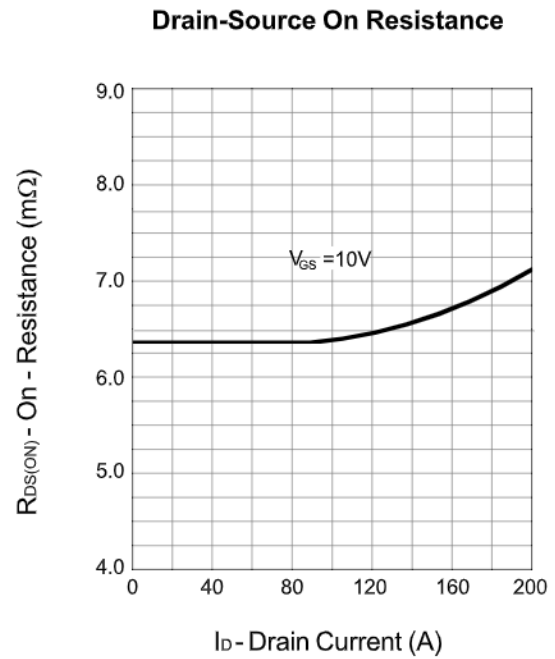
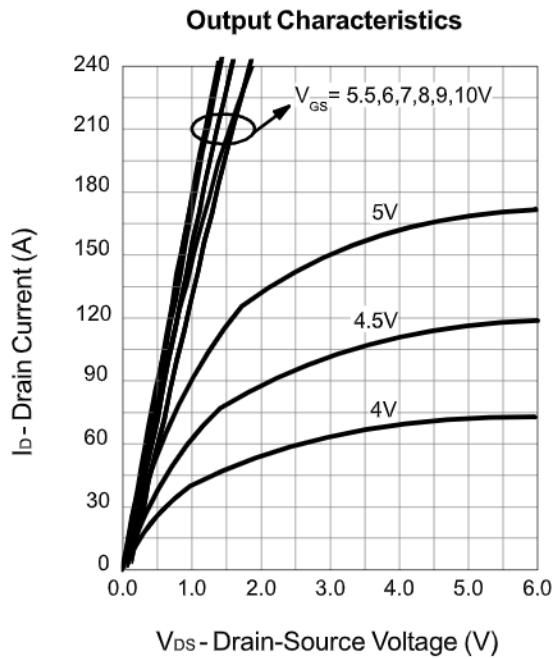

**Typical Operating Characteristics (Cont.)**

**Drain-Source On Resistance**

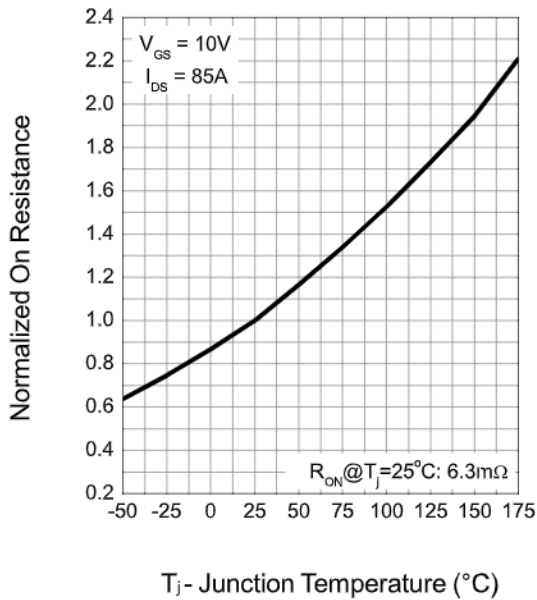

**Source-Drain Diode Forward**

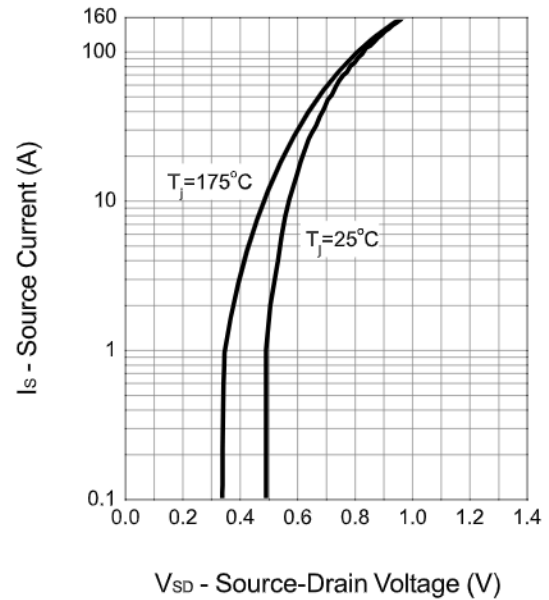

**Capacitance**

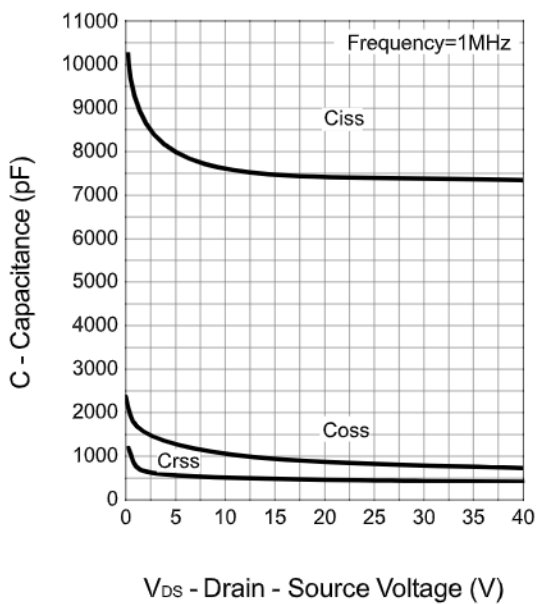

**Gate Charge**

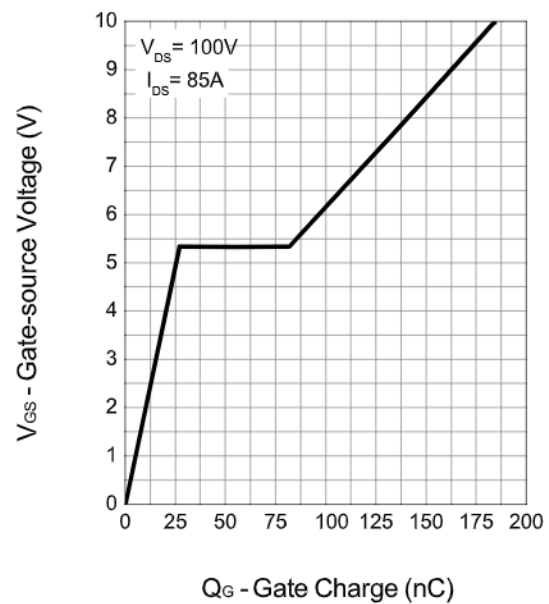

## Avalanche Test Circuit

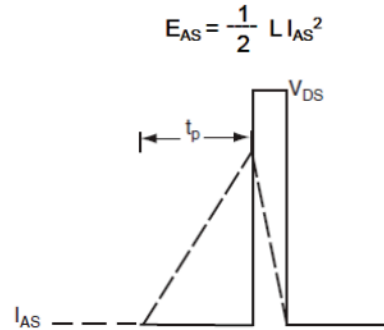
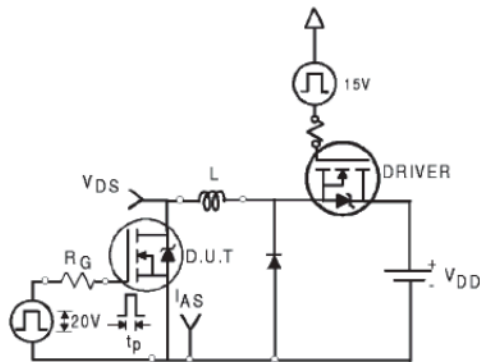

## Switching Time Test Circuit

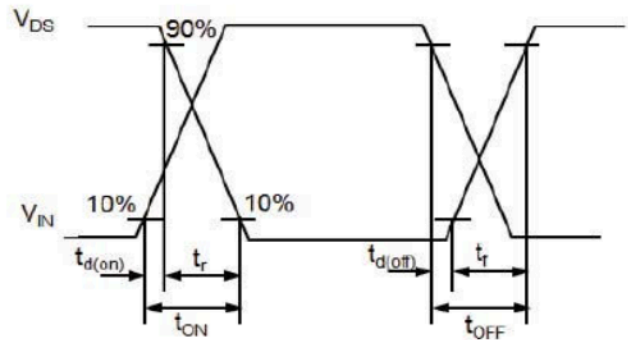
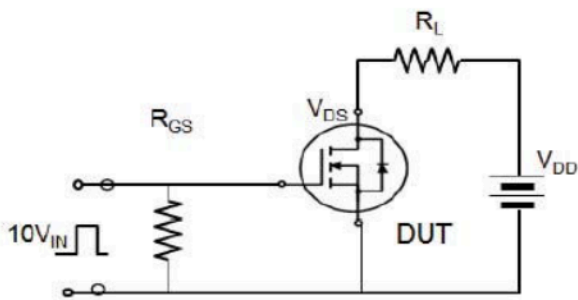

## Gate Charge Test Circuit

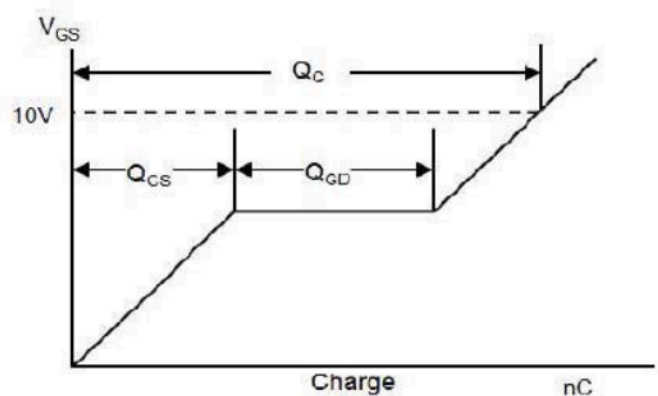
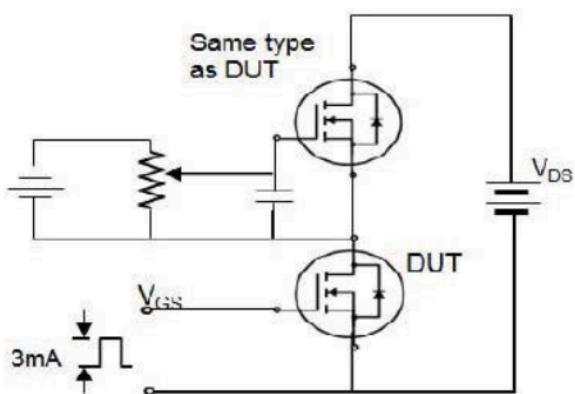

## Device Per Unit

Package Type	Unit	Quantity
TO-247A-3L	Tube	30

## Package Information

TO-247A-3L

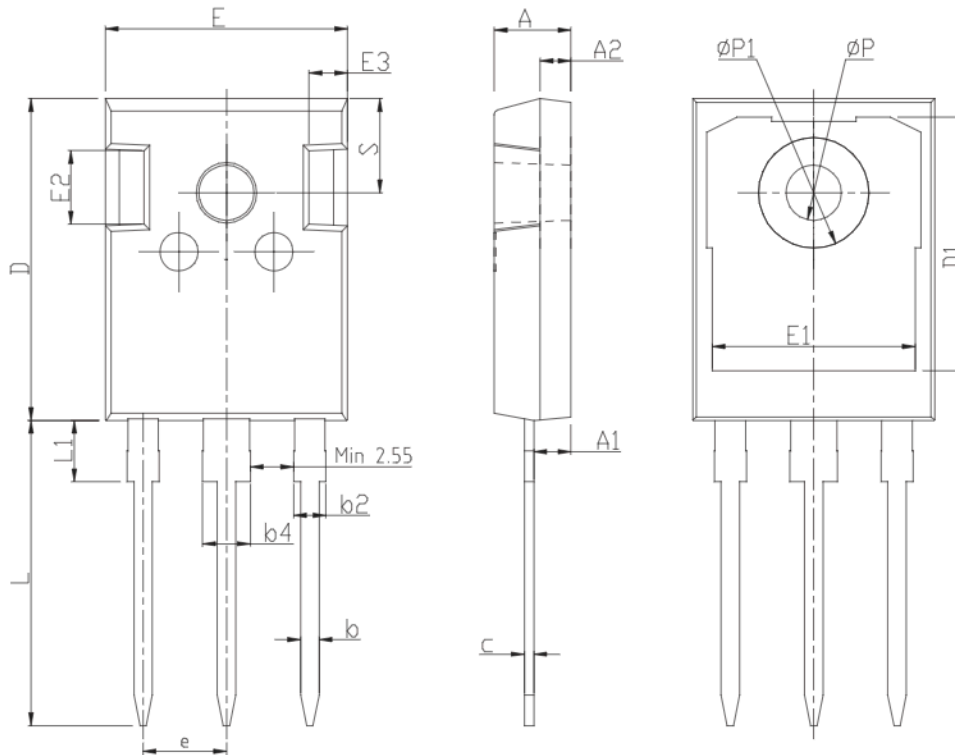

### COMMON DIMENSIONS

SYMBOL	mm		
	MIN	NOM	MAX
A	4.80	5.00	5.20
A1	2.21	2.41	2.61
A2	1.85	2.00	2.15
b	1.11	1.21	1.36
b2	1.91	2.01	2.21
b4	2.91	3.01	3.21
c	0.51	0.61	0.75
D	20.70	21.00	21.30
D1	16.25	16.55	16.85
E	15.50	15.80	16.10
E1	13.00	13.30	13.60
E2	4.80	5.00	5.20
E3	2.30	2.50	2.70
e	5.44BSC		
L	19.62	19.92	20.22
L1	-	-	4.30
P	3.40	3.60	3.80
P1	-	-	7.30
S	6.15BSC		

## Device Per Unit

Package Type	Unit	Quantity
TO-3P-3L	Tube	30

## Package Information

TO-3P-3L

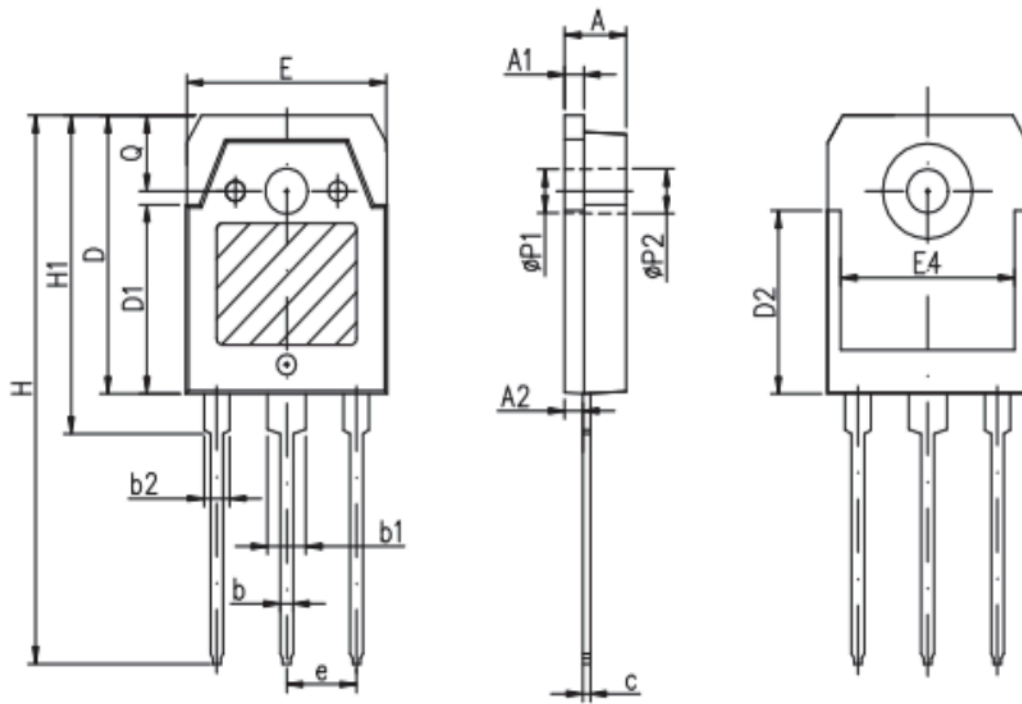

COMMON DIMENSIONS

SYMBOL	mm		
	MIN	NOM	MAX
A	4.60	4.80	5.00
A1	1.40	1.50	1.65
A2	1.18	1.38	1.58
b	0.80	1.00	1.20
b1	2.80	3.00	3.20
b2	1.80	2.00	2.20
c	0.50	0.60	0.75
D	19.60	19.90	20.20
D1	13.55	13.90	14.25
D2	12.90 REF		
E	15.35	15.60	15.85
E4	12.60	-	-
e	5.45 TYP		
H	40.10	40.50	40.90
H1	23.15	23.40	23.65
$\Phi P1$	3.20 REF		
$\Phi P2$	3.50 REF		

**Classification Profile**

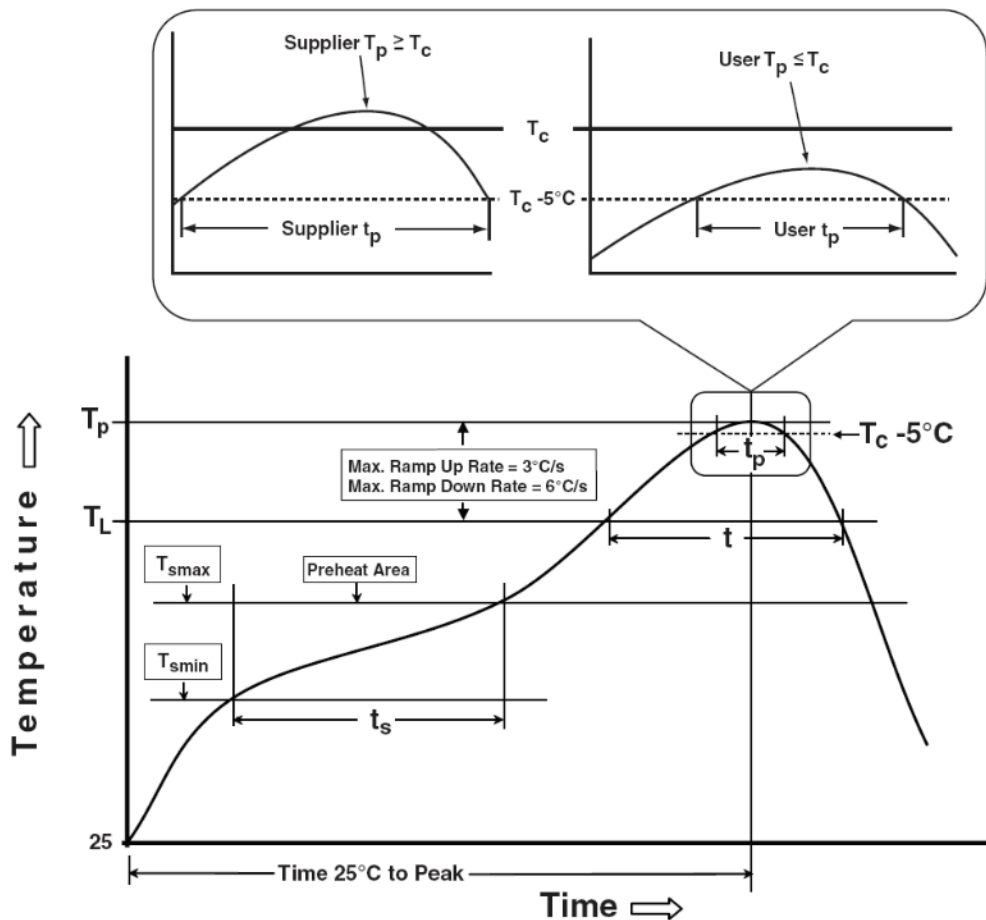

**Classification Reflow Profiles**

Profile Feature	Sn-Pb Eutectic Assembly	Pb-Free Assembly
<b>Preheat &amp; Soak</b>		
Temperature min ( $T_{smin}$ )	100 °C	150 °C
Temperature max ( $T_{smax}$ )	150 °C	200 °C
Time ( $T_{smin}$ to $T_{smax}$ ) ( $t_s$ )	60-120 seconds	60-120 seconds
Average ramp-up rate ( $T_{smax}$ to $T_p$ )	3 °C/second max.	3°C/second max.
Liquidous temperature ( $T_L$ )	183 °C	217 °C
Time at liquidous ( $t_L$ )	60-150 seconds	60-150 seconds
Peak package body Temperature ( $T_p$ )*	See Classification Temp in table 1	See Classification Temp in table 2
Time ( $t_p$ )** within 5°C of the specified classification temperature ( $T_c$ )	20** seconds	30** seconds
Average ramp-down rate ( $T_p$ to $T_{smax}$ )	6 °C/second max.	6 °C/second max.
Time 25°C to peak temperature	6 minutes max.	8 minutes max.
* Tolerance for peak profile Temperature ( $T_p$ ) is defined as a supplier minimum and a user maximum.		
** Tolerance for time at peak profile temperature ( $t_p$ ) is defined as a supplier minimum and a user maximum.		

Table 1. SnPb Eutectic Process – Classification Temperatures (Tc)

Package Thickness	Volume mm <sup>3</sup> <350	Volume mm <sup>3</sup> ≥350
<2.5 mm	235 °C	220 °C
≥2.5 mm	220 °C	220 °C

Table 2. Pb-free Process – Classification Temperatures (Tc)

Package Thickness	Volume mm <sup>3</sup> <350	Volume mm <sup>3</sup> 350-2000	Volume mm <sup>3</sup> >2000
<1.6 mm	260 °C	260 °C	260 °C
1.6 mm – 2.5 mm	260 °C	250 °C	245 °C
≥2.5 mm	250 °C	245 °C	245 °C

## Reliability Test Program

Test Item	Method	Description
SOLDERABILITY	JESD-22, B102	5 Sec, 245°C
HTRB	JESD-22, A108	168 Hrs /500 Hrs /1000 Hrs, Bias @ 150°C
PCT	JESD-22, A102	96Hrs, 100%RH, 2atm, 121°C
TCT	JESD-22, A104	500 Cycles, -55°C~150°C

### Customer Service

Worldwide Sales and Service: [sales@hymexa.com](mailto:sales@hymexa.com)

Technical Support: [Technology@hymexa.com](mailto:Technology@hymexa.com)

Xi'an Huayi Microelectronics Co., Ltd.

No.8928,Shangji Road,Economic and Technological Development Zone,Xi'an,China

TEL: (86-029) 86685706

FAX: (86-029) 86685705

E-mail: [sales@hymexa.com](mailto:sales@hymexa.com)

Web net: [www.hymexa.com](http://www.hymexa.com)