

# LM350

## 3.0 A, Adjustable Output, Positive Voltage Regulator

The LM350 is an adjustable three-terminal positive voltage regulator capable of supplying in excess of 3.0 A over an output voltage range of 1.2 V to 33 V. This voltage regulator is exceptionally easy to use and requires only two external resistors to set the output voltage. Further, it employs internal current limiting, thermal shutdown and safe area compensation, making it essentially blow-out proof.

The LM350 serves a wide variety of applications including local, on card regulation. This device also makes an especially simple adjustable switching regulator, a programmable output regulator, or by connecting a fixed resistor between the adjustment and output, the LM350 can be used as a precision current regulator.

### Features

- Guaranteed 3.0 A Output Current
- Output Adjustable between 1.2 V and 33 V
- Load Regulation Typically 0.1%
- Line Regulation Typically 0.005%/V
- Internal Thermal Overload Protection
- Internal Short Circuit Current Limiting Constant with Temperature
- Output Transistor Safe Area Compensation
- Floating Operation for High Voltage Applications
- Standard 3-lead Transistor Package
- Eliminates Stocking Many Fixed Voltages
- Pb-Free Packages are Available\*

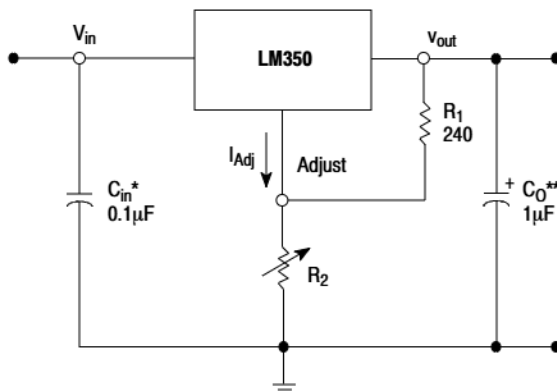

\* =  $C_{in}$  is required if regulator is located an appreciable distance from power supply filter.

\*\* =  $C_o$  is not needed for stability, however, it does improve transient response.

$$V_{out} = 1.25 V \left( 1 + \frac{R_2}{R_1} \right) + I_{Adj} R_2$$

since  $I_{Adj}$  is controlled to less than 100  $\mu$ A, the error associated with this term is negligible in most applications

Figure 1. Simplified Application

\*For additional information on our Pb-Free strategy and soldering details, please download the ON Semiconductor Soldering and Mounting Techniques Reference Manual, SOLDERRM/D.



ON Semiconductor®

<http://onsemi.com>

### THREE-TERMINAL ADJUSTABLE POSITIVE VOLTAGE REGULATOR

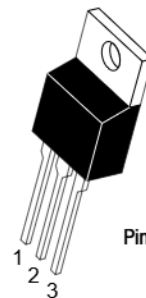

TO-220  
T SUFFIX  
PLASTIC PACKAGE  
CASE 221AB

Pin 1. Adjust  
2.  $V_{out}$   
3.  $V_{in}$

Heatsink surface is connected to Pin 2.

### MARKING DIAGRAM



A = Assembly Location  
WL = Wafer Lot  
Y = Year  
WW = Work Week  
G = Pb-Free Device

### ORDERING INFORMATION

See detailed ordering and shipping information in the package dimensions section on page 3 of this data sheet.

# LM350

## MAXIMUM RATINGS

Rating	Symbol	Value	Unit
Input-Output Voltage Differential	$V_I - V_O$	35	Vdc
Power Dissipation	$P_D$	Internally Limited	W
Operating Junction Temperature Range	$T_J$	-40 to +125	°C
Storage Temperature Range	$T_{stg}$	-65 to +150	°C
Soldering Lead Temperature (10 seconds)	$T_{solder}$	300	°C

Stresses exceeding Maximum Ratings may damage the device. Maximum Ratings are stress ratings only. Functional operation above the Recommended Operating Conditions is not implied. Extended exposure to stresses above the Recommended Operating Conditions may affect device reliability.

## ELECTRICAL CHARACTERISTICS ( $V_I - V_O = 5.0\text{ V}$ ; $I_L = 1.5\text{ A}$ ; $T_J = T_{low}$ to $T_{high}$ ; $P_{max}$ [Note 1], unless otherwise noted.)

Characteristics	Figure	Symbol	Min	Typ	Max	Unit
Line Regulation (Note 2) $T_A = 25^\circ\text{C}$ , $3.0\text{ V} \leq V_I - V_O \leq 35\text{ V}$	1	$Reg_{line}$	-	0.0005	0.03	%/V
Load Regulation (Note 2) $T_A = 25^\circ\text{C}$ , $10\text{ mA} \leq I_L \leq 3.0\text{ A}$ $V_O \leq 5.0\text{ V}$ $V_O \geq 5.0\text{ V}$	2	$Reg_{load}$	-	5.0 0.1	25 0.5	mV % $V_O$
Thermal Regulation, Pulse = 20 ms, ( $T_A = +25^\circ\text{C}$ )		$Reg_{therm}$	-	0.002	-	% $V_O$ /W
Adjustment Pin Current	3	$I_{Adj}$	-	50	100	$\mu\text{A}$
Adjustment Pin Current Change $3.0\text{ V} \leq V_I - V_O \leq 35\text{ V}$ $10\text{ mA} \leq I_L \leq 3.0\text{ A}$ , $P_D \leq P_{max}$	1,2	$\Delta I_{Adj}$	-	0.2	5.0	$\mu\text{A}$
Reference Voltage $3.0\text{ V} \leq V_I - V_O \leq 35\text{ V}$ $10\text{ mA} \leq I_O \leq 3.0\text{ A}$ , $P_D \leq P_{max}$	3	$V_{ref}$	1.20	1.25	1.30	V
Line Regulation (Note 2) $3.0\text{ V} \leq V_I - V_O \leq 35\text{ V}$	1	$Reg_{line}$	-	0.02	0.07	%/V
Load Regulation (Note 2) $10\text{ mA} \leq I_L \leq 3.0\text{ A}$ $V_O \leq 5.0\text{ V}$ $V_O \geq 5.0\text{ V}$	2	$Reg_{load}$	-	20 0.3	70 1.5	mV % $V_O$
Temperature Stability ( $T_{low} \leq T_J \leq T_{high}$ )	3	$T_S$	-	1.0	-	% $V_O$
Minimum Load Current to Maintain Regulation ( $V_I - V_O = 35\text{ V}$ )	3	$I_{Lmin}$	-	3.5	10	mA
Maximum Output Current $V_I - V_O \leq 10\text{ V}$ , $P_D \leq P_{max}$ $V_I - V_O = 30\text{ V}$ , $P_D \leq P_{max}$ , $T_A = 25^\circ\text{C}$	3	$I_{max}$	3.0 0.25	4.5 1.0	- -	A
RMS Noise, % of $V_O$ $T_A = 25^\circ\text{C}$ , $10\text{ Hz} \leq f \leq 10\text{ kHz}$		N	-	0.003	-	% $V_O$
Ripple Rejection, $V_O = 10\text{ V}$ , $f = 120\text{ Hz}$ (Note 3) Without $C_{Adj}$ $C_{Adj} = 10\text{ }\mu\text{F}$	4	RR	-	65 66	- 80	dB
Long Term Stability, $T_J = T_{high}$ (Note 4) $T_A = 25^\circ\text{C}$ for Endpoint Measurements	3	S	-	0.3	1.0	%/1.0 k Hrs.
Thermal Resistance, Junction-to-Case Peak (Note 5) Average (Note 6)		$R_{\theta JC}$	-	2.3 -	- 1.5	°C/W

- $T_{low}$  to  $T_{high} = 0^\circ$  to  $+125^\circ\text{C}$ ;  $P_{max} = 25\text{ W}$  for LM350T;  $T_{low}$  to  $T_{high} = -40^\circ$  to  $+125^\circ\text{C}$ ;  $P_{max} = 25\text{ W}$  for LM350BT
- Load and line regulation are specified at constant junction temperature. Changes in  $V_O$  due to heating effects must be taken into account separately. Pulse testing with low duty cycle is used.
- $C_{Adj}$ , when used, is connected between the adjustment pin and ground.
- Since Long-Term Stability cannot be measured on each device before shipment, this specification is an engineering estimate of average stability from lot to lot.
- Thermal Resistance evaluated measuring the hottest temperature on the die using an infrared scanner. This method of evaluation yields very accurate thermal resistance values which are conservative when compared to the other measurement techniques.
- The average die temperature is used to derive the value of thermal resistance junction to case (average).

# LM350

## ORDERING INFORMATION

Device	Operating Temperature Range	Package	Shipping†
LM350T	T <sub>J</sub> = 0° to + 125 °C	TO-220	50 Units / Rail
LM350TG		TO-220 (Pb-Free)	50 Units / Rail

†For information on tape and reel specifications, including part orientation and tape sizes, please refer to our Tape and Reel Packaging Specifications Brochure, BRD8011/D.

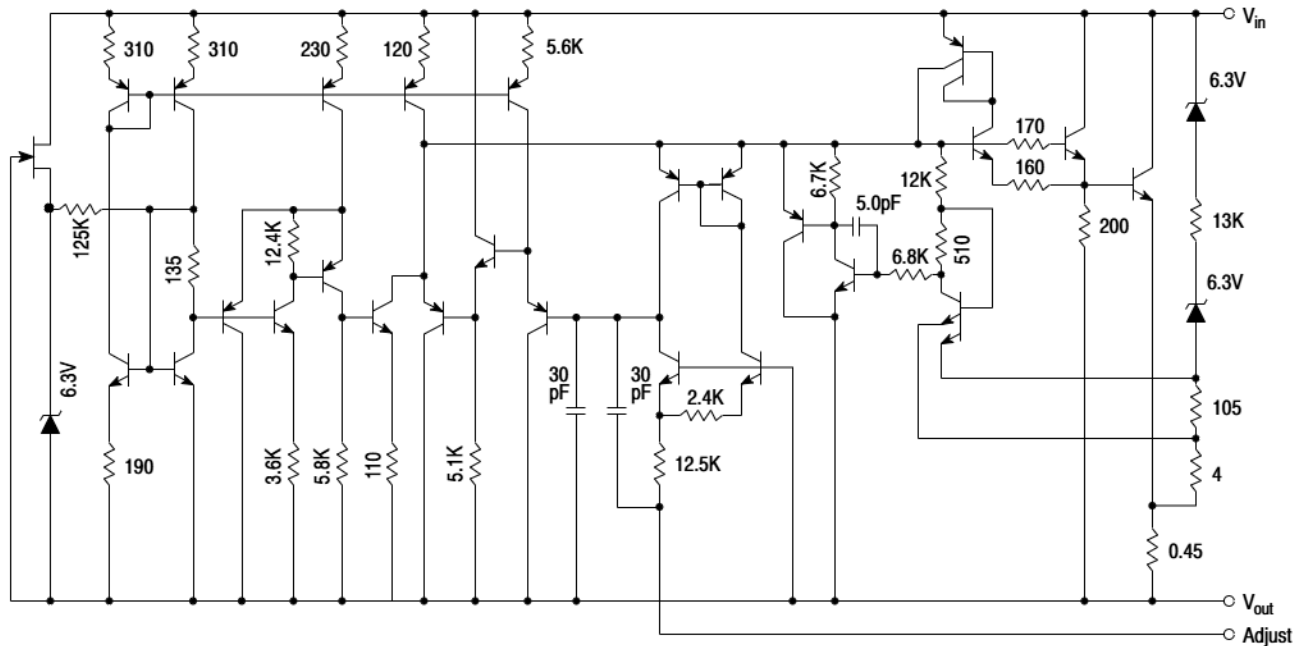

Figure 2. Representative Schematic Diagram

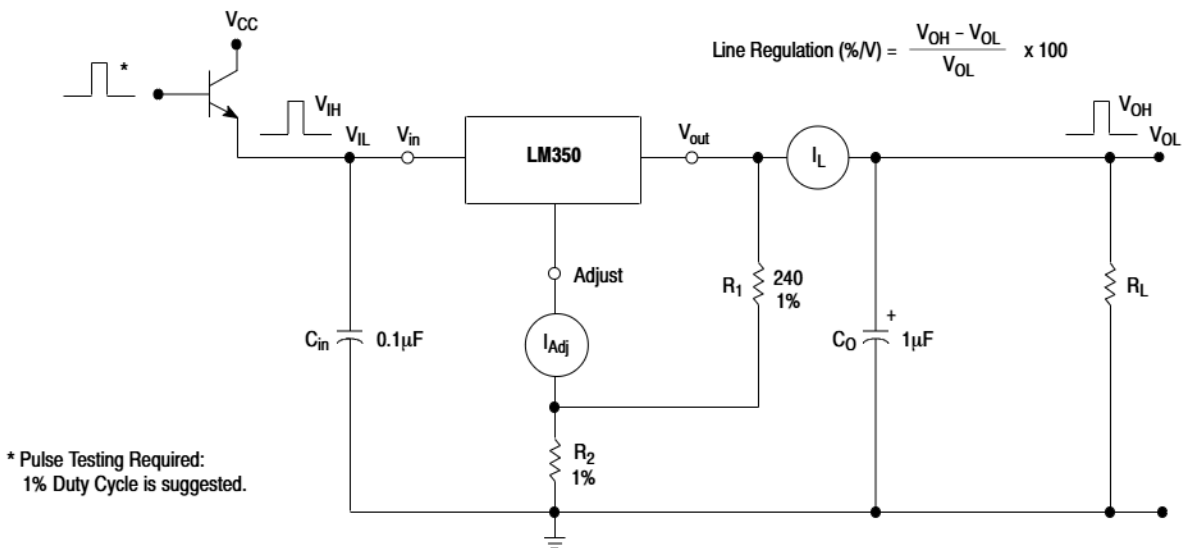

Figure 3. Line Regulation and  $\Delta I_{Adj}/Line$  Test Circuit

# LM350

$$\text{Load Regulation (\% } V_O) = \frac{V_O (\text{min Load}) - V_O (\text{max Load})}{V_O (\text{min Load})} \times 100$$

$$\text{Load Regulation (mV)} = V_O (\text{min Load}) - V_O (\text{max Load})$$

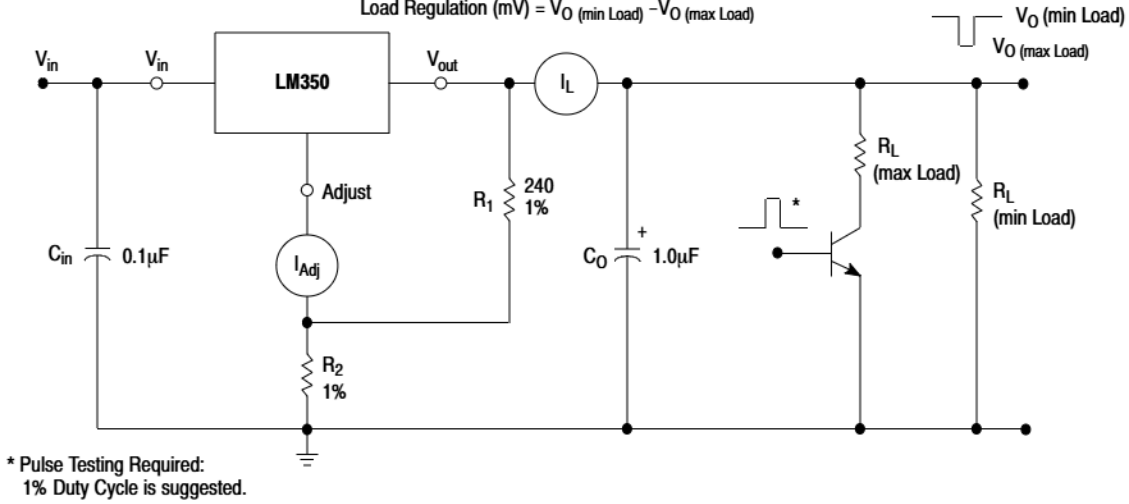
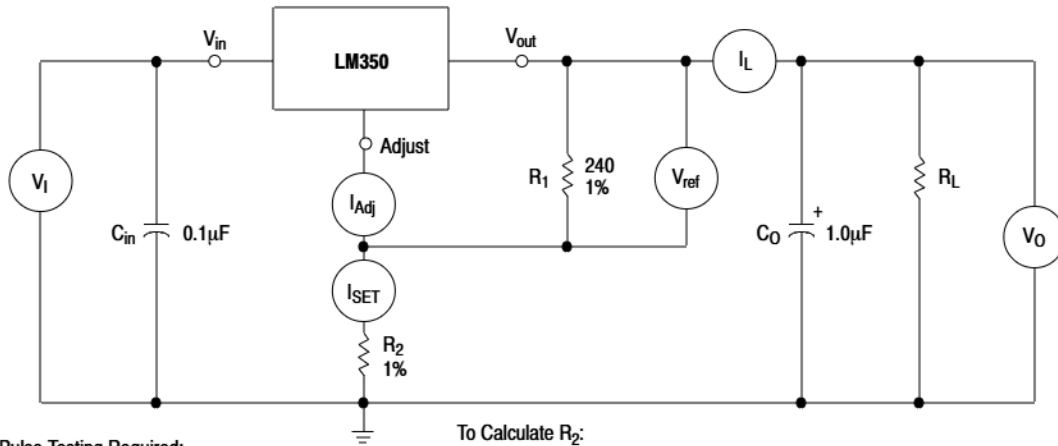

Figure 4. Load Regulation and  $\Delta I_{Adj}$ /Load Test Circuit



To Calculate  $R_2$ :  
 $V_{out} = I_{SET} R_2 + 1.250 \text{ V}$   
 Assume  $I_{SET} = 5.25 \text{ mA}$

Figure 5. Standard Test Circuit

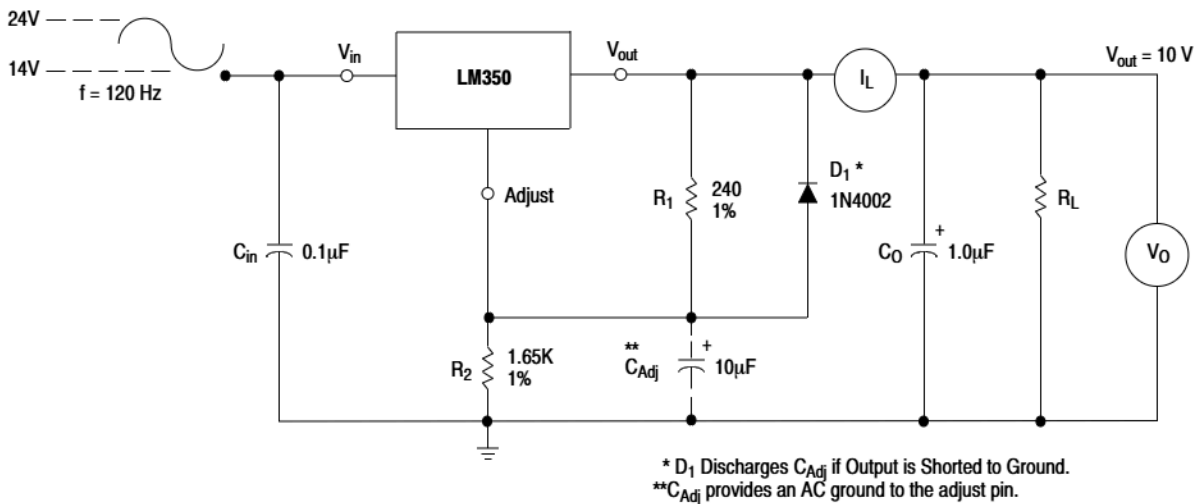

Figure 6. Ripple Rejection Test Circuit

# LM350

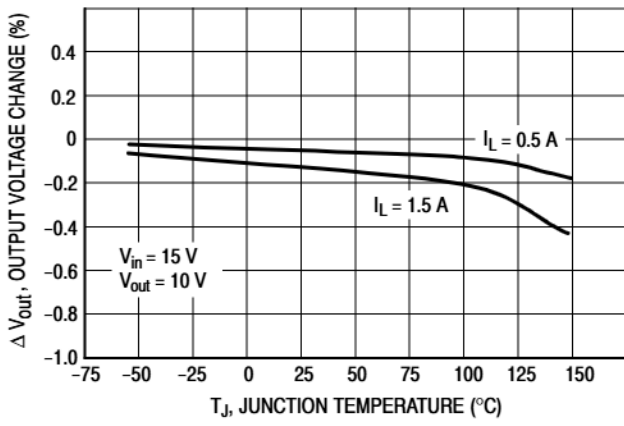

Figure 7. Load Regulation

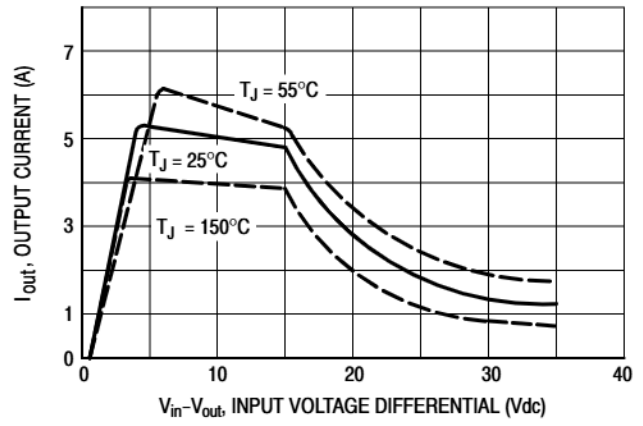

Figure 8. Current Limit

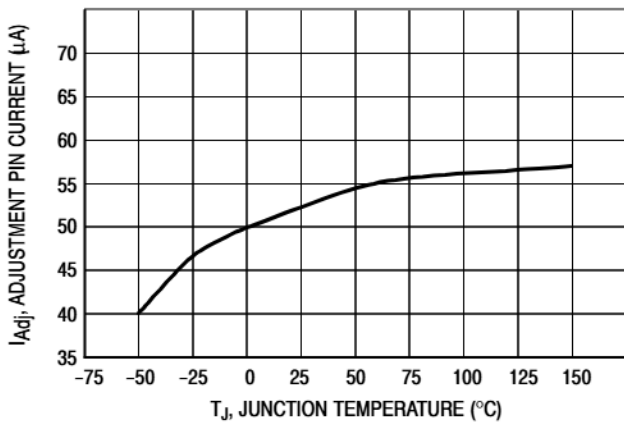

Figure 9. Adjustment Pin Current

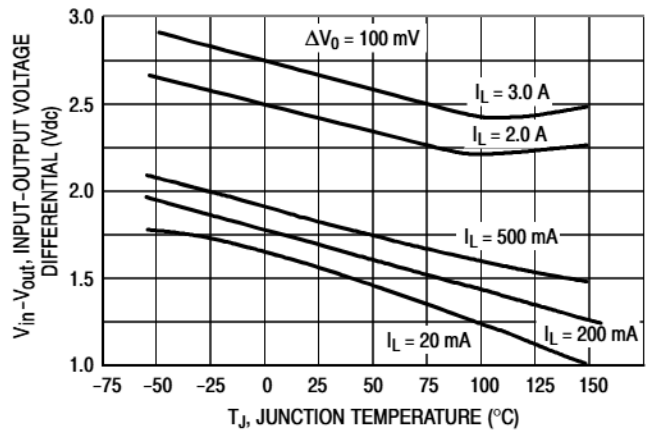

Figure 10. Dropout Voltage

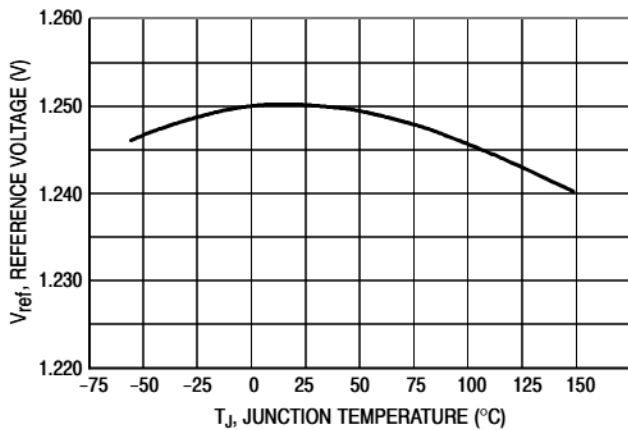

Figure 11. Temperature Stability

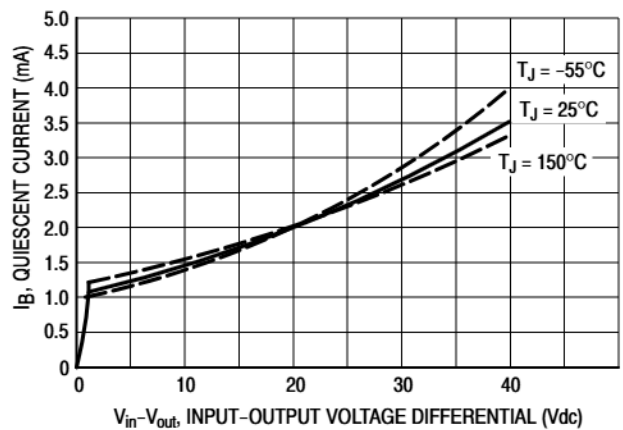

Figure 12. Minimum Operating Current

# LM350

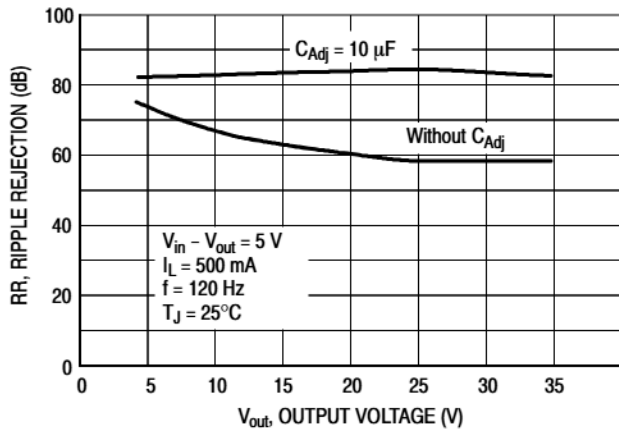

Figure 13. Ripple Rejection versus Output Voltage

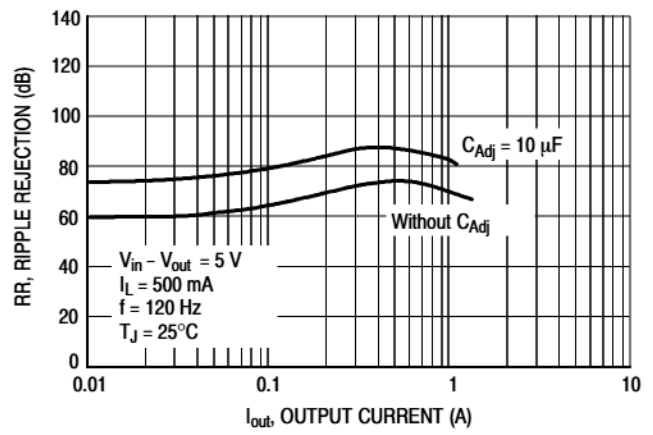

Figure 14. Ripple Rejection versus Output Current

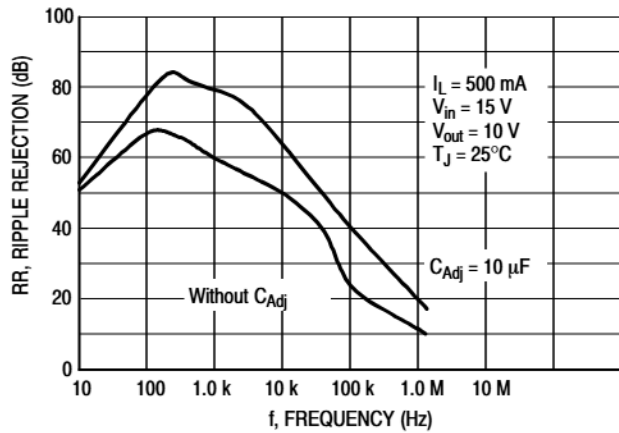

Figure 15. Ripple Rejection versus Frequency

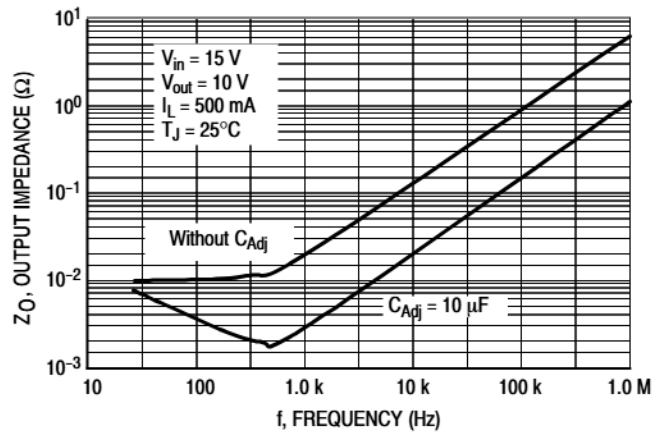

Figure 16. Output Impedance

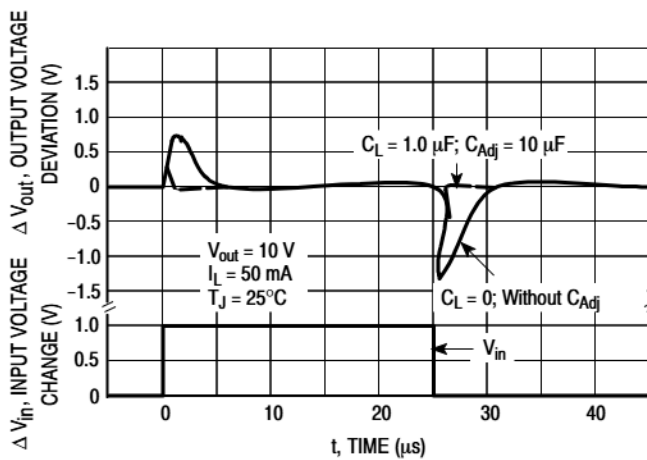

Figure 17. Line Transient Response

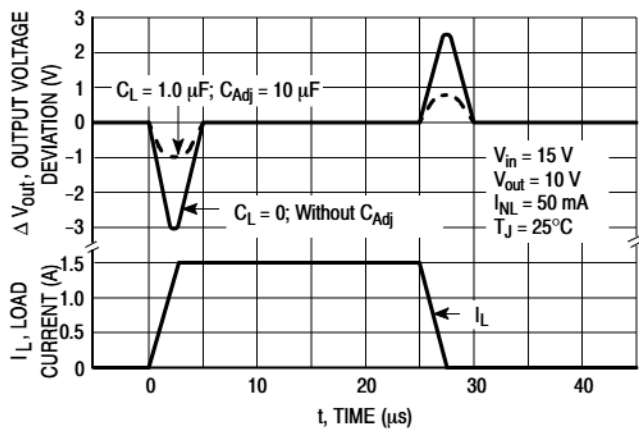

Figure 18. Load Transient Response

## APPLICATIONS INFORMATION

## Basic Circuit Operation

The LM350 is a three-terminal floating regulator. In operation, the LM350 develops and maintains a nominal 1.25 V reference ( $V_{ref}$ ) between its output and adjustment terminals. This reference voltage is converted to a programming current ( $I_{PROG}$ ) by  $R_1$  (see Figure 19), and this constant current flows through  $R_2$  to ground. The regulated output voltage is given by:

$$V_{out} = V_{ref} \left( 1 + \frac{R_2}{R_1} \right) + I_{Adj} R_2$$

Since the current from the terminal ( $I_{Adj}$ ) represents an error term in the equation, the LM350 was designed to control  $I_{Adj}$  to less than 100  $\mu$ A and keep it constant. To do this, all quiescent operating current is returned to the output terminal. This imposes the requirement for a minimum load current. If the load current is less than this minimum, the output voltage will rise.

Since the LM350 is a floating regulator, it is only the voltage differential across the circuit which is important to performance, and operation at high voltages with respect to ground is possible.

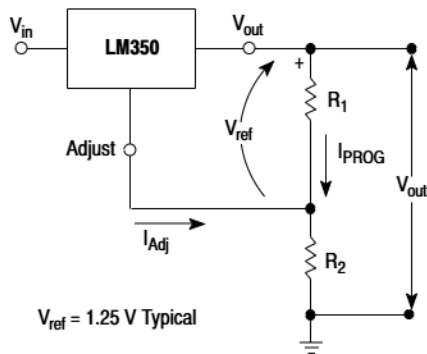

Figure 19. Basic Circuit Configuration

## Load Regulation

The LM350 is capable of providing extremely good load regulation, but a few precautions are needed to obtain maximum performance. For best performance, the programming resistor ( $R_1$ ) should be connected as close to the regulator as possible to minimize line drops which effectively appear in series with the reference, thereby degrading regulation. The ground end of  $R_2$  can be returned near the load ground to provide remote ground sensing and improve load regulation.

## External Capacitors

A 0.1  $\mu$ F disc or 1  $\mu$ F tantalum input bypass capacitor ( $C_{in}$ ) is recommended to reduce the sensitivity to input line impedance.

The adjustment terminal may be bypassed to ground to improve ripple rejection. This capacitor ( $C_{Adj}$ ) prevents ripple from being amplified as the output voltage is increased. A 10  $\mu$ F capacitor should improve ripple rejection about 15 dB at 120 Hz in a 10 V application.

Although the LM350 is stable with no output capacitance, like any feedback circuit, certain values of external capacitance can cause excessive ringing. An output capacitance ( $C_O$ ) in the form of a 1  $\mu$ F tantalum or 25  $\mu$ F aluminum electrolytic capacitor on the output swamps this effect and insures stability.

## Protection Diodes

When external capacitors are used with any IC regulator, it is sometimes necessary to add protection diodes to prevent the capacitors from discharging through low current points into the regulator.

Figure 18 shows the LM350 with the recommended protection diodes for output voltages in excess of 25 V or high capacitance values ( $C_O > 25 \mu$ F,  $C_{Adj} > 10 \mu$ F). Diode  $D_1$  prevents  $C_O$  from discharging thru the IC during an input short circuit. Diode  $D_2$  protects against capacitor  $C_{Adj}$  discharging through the IC during an output short circuit. The combination of diodes  $D_1$  and  $D_2$  prevents  $C_{Adj}$  from discharging through the IC during an input short circuit.

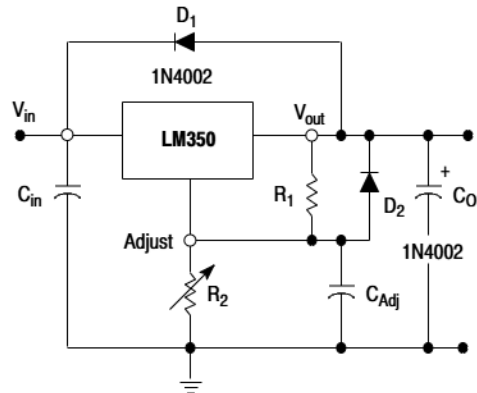

Figure 20. Voltage Regulator with Protection Diodes

# LM350

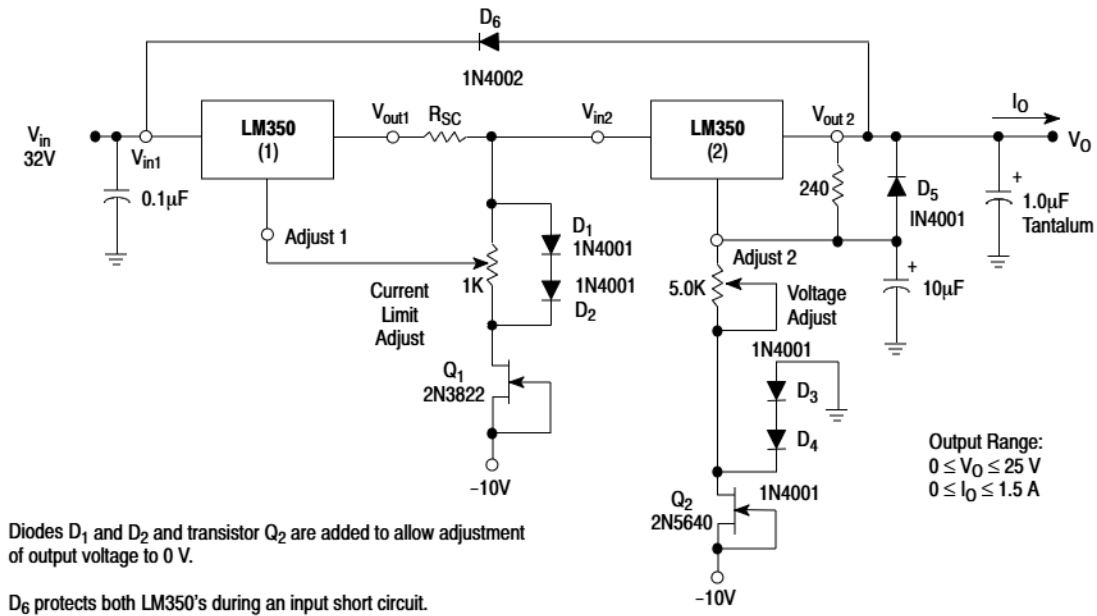

Figure 21. "Laboratory" Power Supply with Adjustable Current Limit and Output Voltage

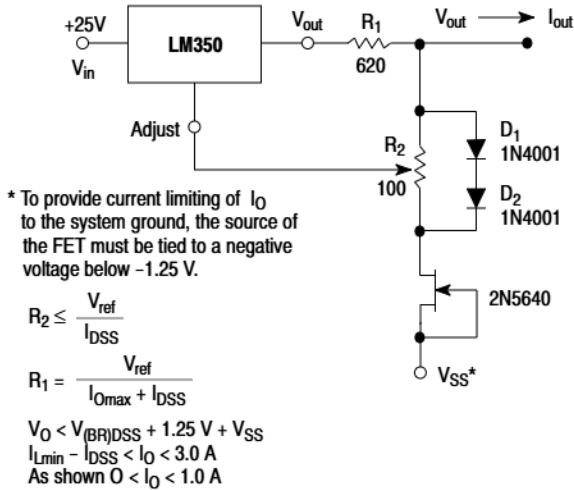
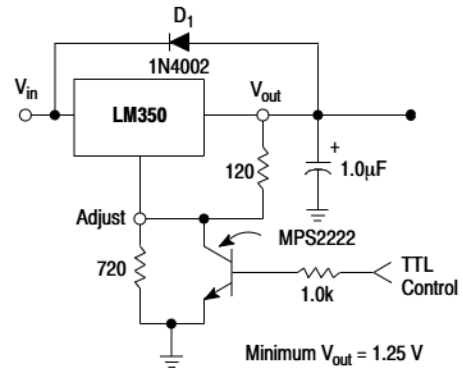

Figure 22. Adjustable Current Limiter



D<sub>1</sub> protects the device during an input short circuit.

Figure 23. 5.0 V Electronic Shutdown Regulator

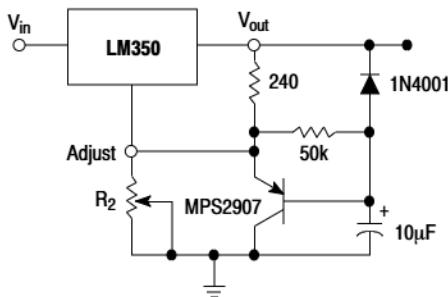

Figure 24. Slow Turn-On Regulator

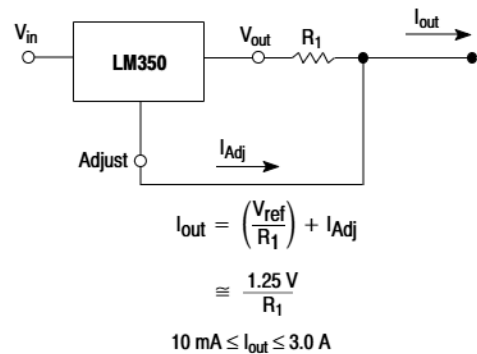
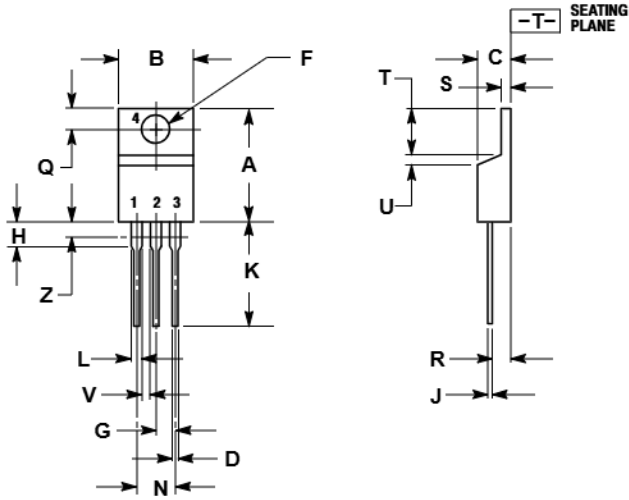

Figure 25. Current Regulator

# LM350

## PACKAGE DIMENSIONS

TO-220, SINGLE GAUGE  
T SUFFIX  
CASE 221AB-01  
ISSUE O



**NOTES:**

1. DIMENSIONING AND TOLERANCING PER ANSI Y14.5M, 1982.
2. CONTROLLING DIMENSION: INCH.
3. DIMENSION Z DEFINES A ZONE WHERE ALL BODY AND LEAD IRREGULARITIES ARE ALLOWED.

DIM	INCHES		MILLIMETERS	
	MIN	MAX	MIN	MAX
A	0.570	0.620	14.48	15.75
B	0.380	0.405	9.66	10.28
C	0.160	0.190	4.07	4.82
D	0.025	0.035	0.64	0.88
F	0.142	0.147	3.61	3.73
G	0.095	0.105	2.42	2.66
H	0.110	0.155	2.80	3.93
J	0.018	0.025	0.46	0.64
K	0.500	0.562	12.70	14.27
L	0.045	0.060	1.15	1.52
N	0.190	0.210	4.83	5.33
Q	0.100	0.120	2.54	3.04
R	0.080	0.110	2.04	2.79
S	0.020	0.055	0.508	1.39
T	0.235	0.255	5.97	6.47
U	0.000	0.050	0.00	1.27
V	0.045	---	1.15	---
Z	---	0.080	---	2.04

# LM350

ON Semiconductor and  are registered trademarks of Semiconductor Components Industries, LLC (SCILLC). SCILLC reserves the right to make changes without further notice to any products herein. SCILLC makes no warranty, representation or guarantee regarding the suitability of its products for any particular purpose, nor does SCILLC assume any liability arising out of the application or use of any product or circuit, and specifically disclaims any and all liability, including without limitation special, consequential or incidental damages. "Typical" parameters which may be provided in SCILLC data sheets and/or specifications can and do vary in different applications and actual performance may vary over time. All operating parameters, including "Typicals" must be validated for each customer application by customer's technical experts. SCILLC does not convey any license under its patent rights nor the rights of others. SCILLC products are not designed, intended, or authorized for use as components in systems intended for surgical implant into the body, or other applications intended to support or sustain life, or for any other application in which the failure of the SCILLC product could create a situation where personal injury or death may occur. Should Buyer purchase or use SCILLC products for any such unintended or unauthorized application, Buyer shall indemnify and hold SCILLC and its officers, employees, subsidiaries, affiliates, and distributors harmless against all claims, costs, damages, and expenses, and reasonable attorney fees arising out of, directly or indirectly, any claim of personal injury or death associated with such unintended or unauthorized use, even if such claim alleges that SCILLC was negligent regarding the design or manufacture of the part. SCILLC is an Equal Opportunity/Affirmative Action Employer. This literature is subject to all applicable copyright laws and is not for resale in any manner.

## PUBLICATION ORDERING INFORMATION

### LITERATURE FULFILLMENT:

Literature Distribution Center for ON Semiconductor  
P.O. Box 5163, Denver, Colorado 80217 USA  
Phone: 303-675-2175 or 800-344-3860 Toll Free USA/Canada  
Fax: 303-675-2176 or 800-344-3867 Toll Free USA/Canada  
Email: [orderlit@onsemi.com](mailto:orderlit@onsemi.com)

**N. American Technical Support:** 800-282-9855 Toll Free  
USA/Canada  
**Europe, Middle East and Africa Technical Support:**  
Phone: 421 33 790 2910  
**Japan Customer Focus Center**  
Phone: 81-3-5773-3850

**ON Semiconductor Website:** [www.onsemi.com](http://www.onsemi.com)

**Order Literature:** <http://www.onsemi.com/orderlit>

For additional information, please contact your local Sales Representative