

2SC930

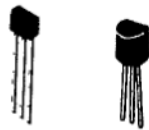

2033 2003A

NPN Epitaxial Planar Silicon Transistor

T-31-15
T-31-17

AM Converter, FM RF · IF Amp Applications

©545E

The 2SC930 has two types of package: SPA and NP.

Use

- FM RF amp, mixer, OSC, converter, and IF amplifier.

Absolute Maximum Ratings at Ta=25°C		2SC930SPA	2SC930NP	unit
Collector to Base Voltage	V _{CBO}	30	30	V
Collector to Emitter Voltage	V _{CEO}	20	20	V
Emitter to Base Voltage	V _{EBO}	5	5	V
Collector Current	I _C	30	30	mA
Collector Dissipation	P _C	120	250	mW
Junction Temperature	T _j	125	125	°C
Storage Temperature	T _{stg}	-40 to +125	-55 to +125	°C

Electrical Characteristics at Ta=25°C					min	typ	max	unit
Collector Cutoff Current	I _{CBO}	V _{CB} =10V, I _E =0					1	uA
Emitter Cutoff Current	I _{EBO}	V _{EB} =4V, I _C =0					1	uA
DC Current Gain	h _{FE}	V _{CE} =6V, I _C =1mA	40*	80	320*			
Gain Bandwidth Product	f _T	V _{CE} =6V, I _C =1mA	170	300				MHz
Reverse Transfer capacitance	C _{re}	V _{CB} =6V, I _C =1MHz (2SC930SPA)	0.8			1.6		pF
		V _{CB} =6V, f=1MHz (2SC930NP)	1.0	1.3	1.8			pF
Base to Collector Time Constant	τ _{bb'cc}	V _{CE} =6V, I _C =1mA		20	36			ps
		f=31.9MHz						
Noise Figure	N _F	V _{CE} =6V, I _C =1mA		4.0				dB
		f=100MHz						
Turn-on Time	t _{on}	V _{IN} =+12V, V _{BB} =-3V, appointed circuit		30				ns
Turn-off Time	t _{off}	V _{IN} =-12V, V _{BB} =+3V, appointed circuit		30				ns

*The 2SC930 is graded as follows by mA h_{FE}:

40	C	80	60	D	120	100	E	200	160	F	320
----	---	----	----	---	-----	-----	---	-----	-----	---	-----

Case Outline 2033 (unit:mm)

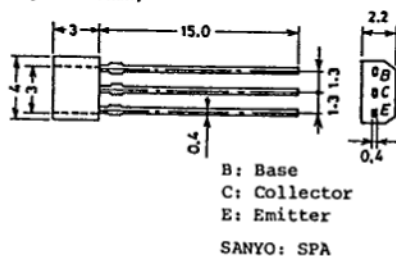

Case Outline 2003A (unit:mm)

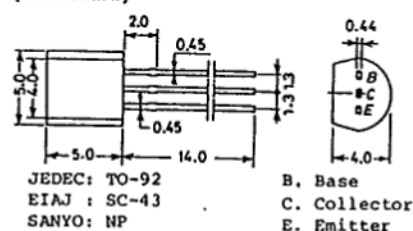

The 2SC930 is scheduled to be discontinued soon. Use the 2SC2839, instead of the 2SC930, in new applications where you are planning to use the 2SC930.

CASE OUTLINES AND ATTACHMENTS

- All of Sanyo Transistor case outlines are illustrated below.
- All dimensions are in mm, and dimensions which are not followed by min. or max. are represented by typical values.
- No marking is indicated.

Case Outline-[2003A]
unit:mm

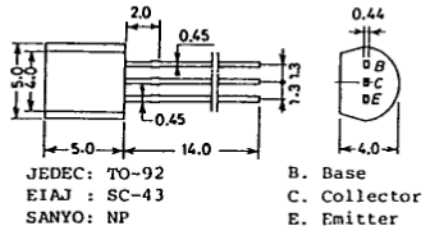

Case Outline-[2009A]
unit:mm

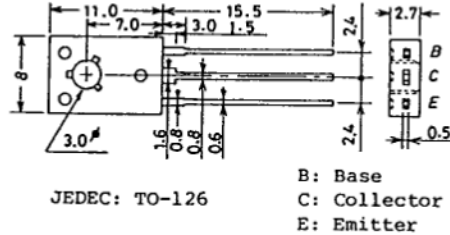

Case Outline-[2004A]
unit:mm

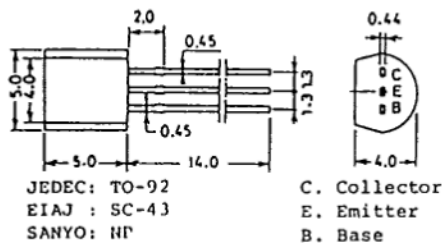

Case Outline-[2010A]
unit:mm

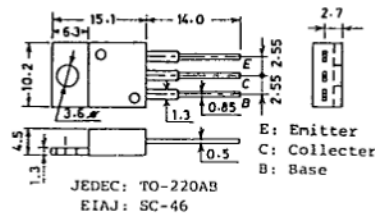

Case Outline-[2005A]
unit:mm

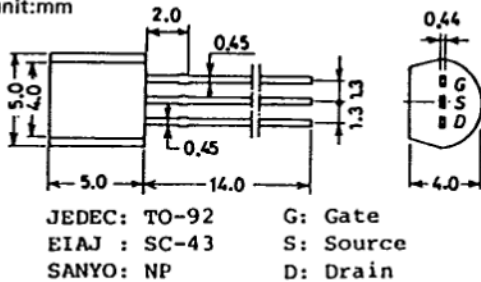

Case Outline-[2012]
unit:mm

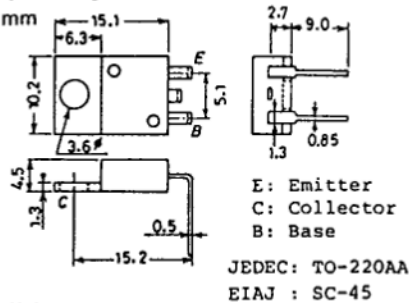

Case Outline-[2006A]
unit:mm

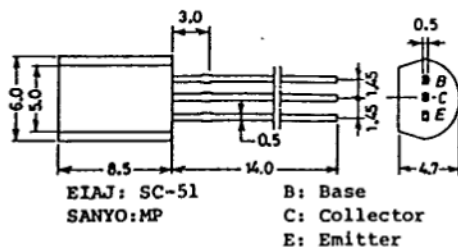

Case Outline-[2013]
unit:mm

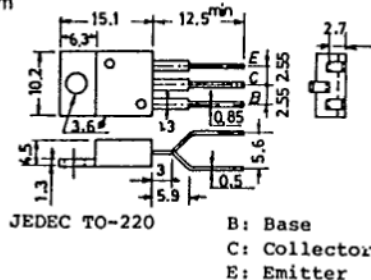

T-91-20

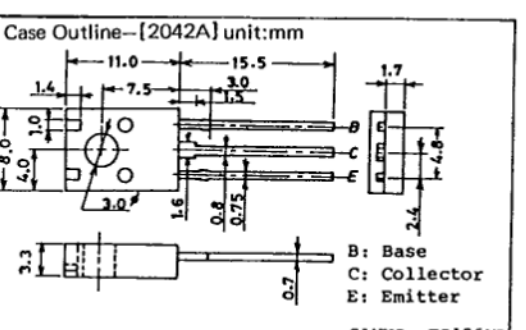
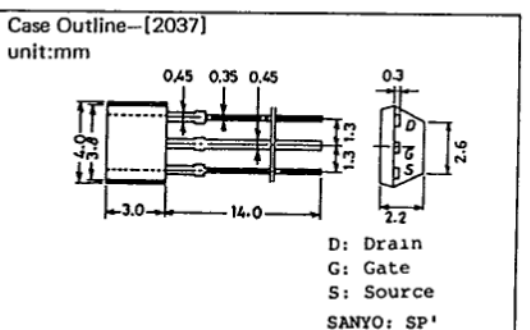
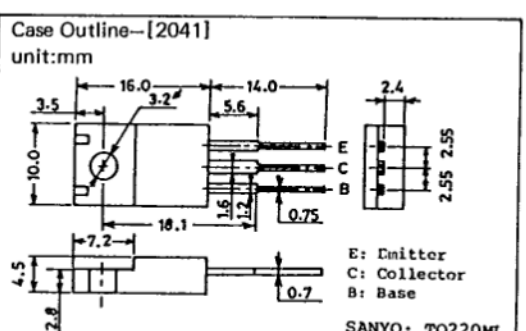
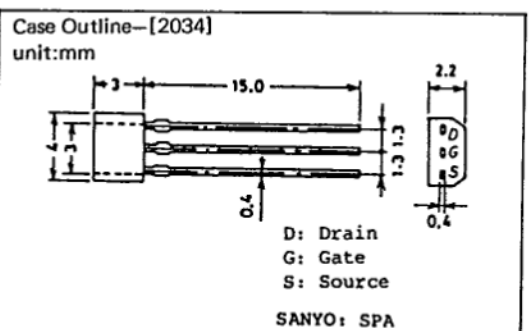
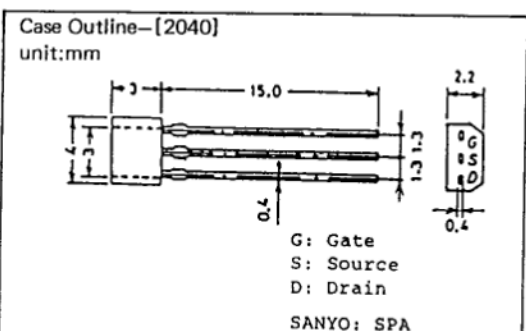
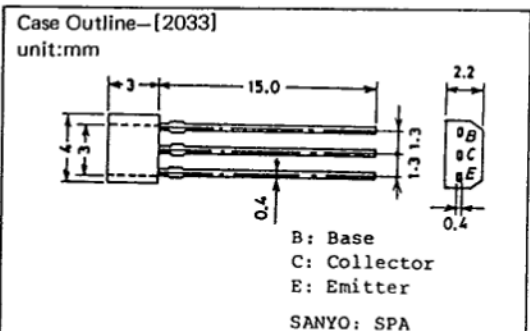
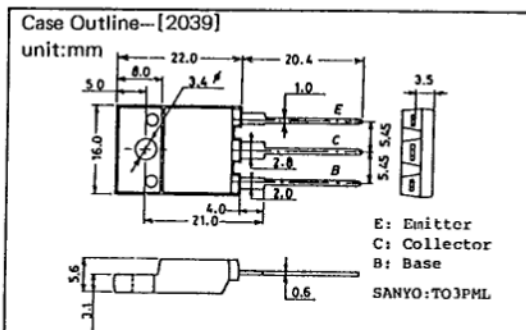
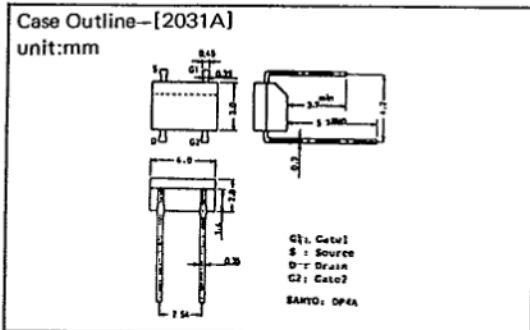
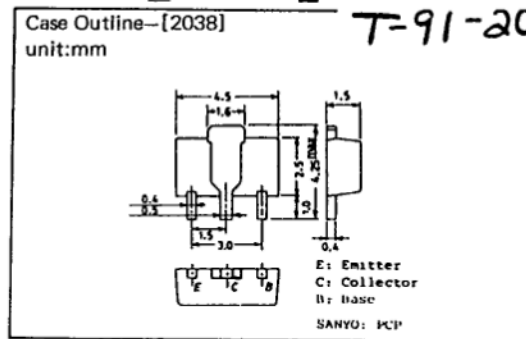
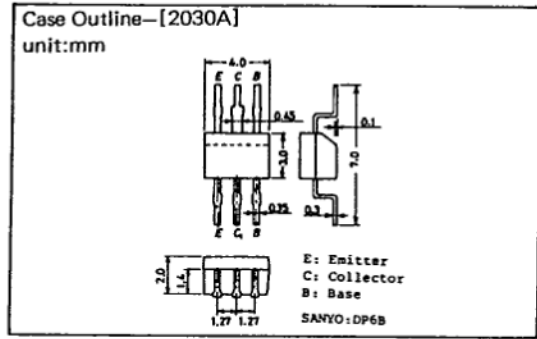

T-91-20

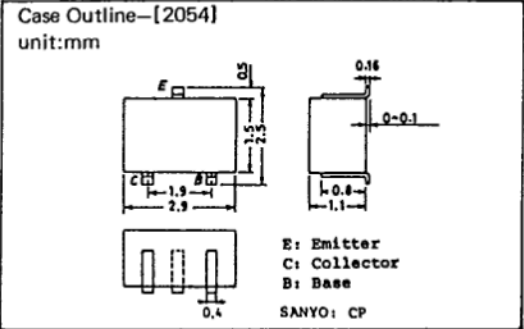
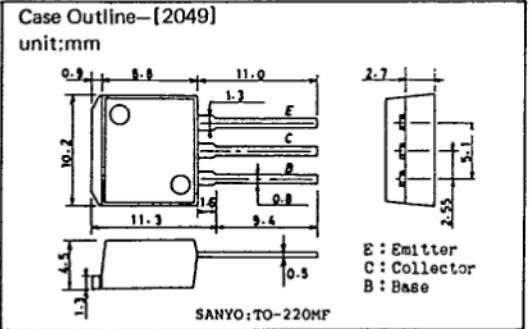
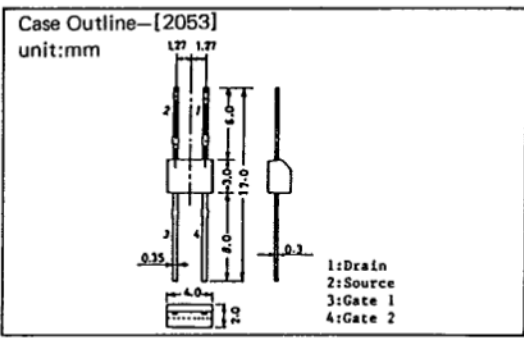
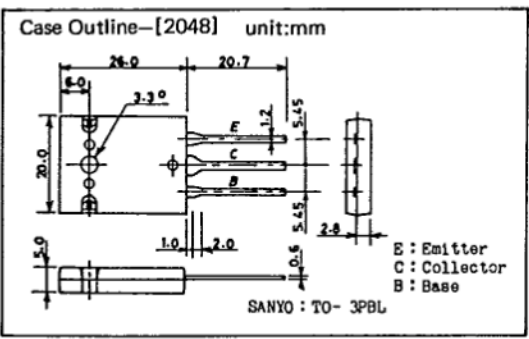
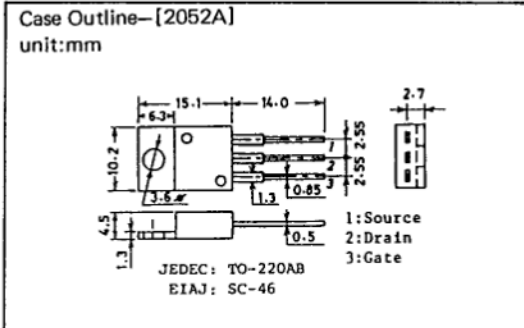
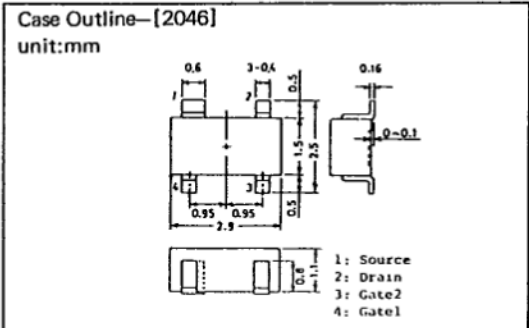
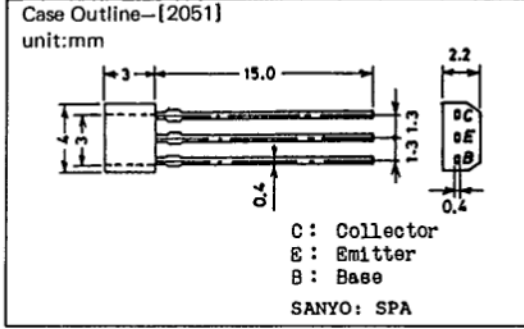
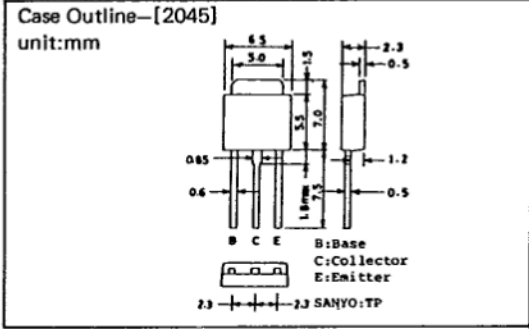
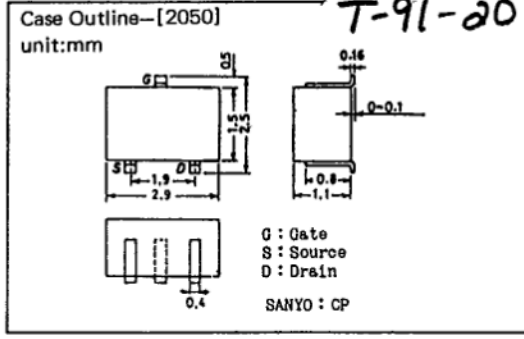
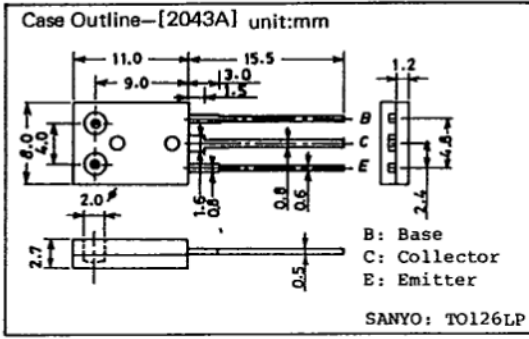

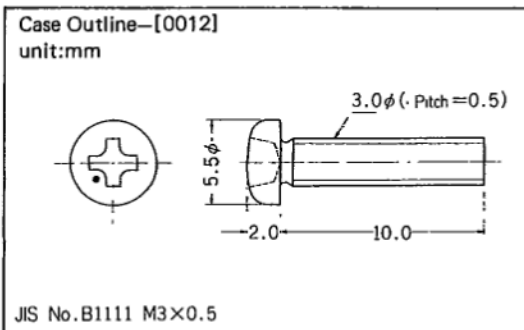
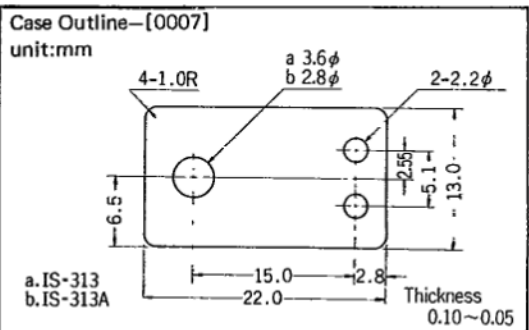
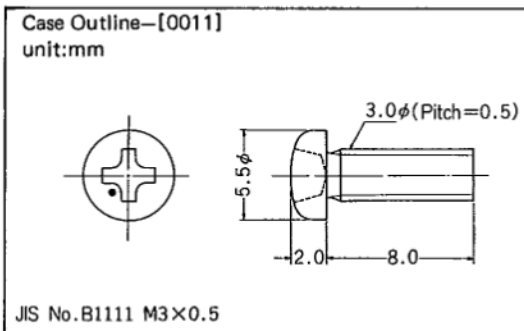
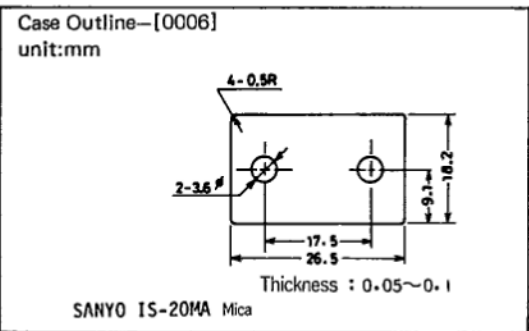
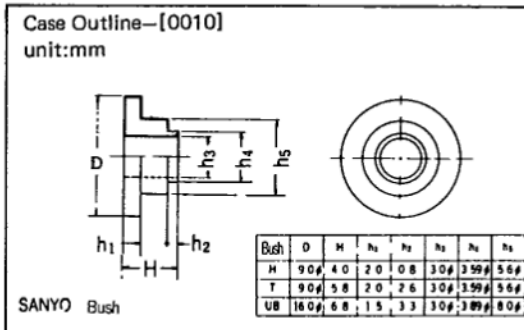
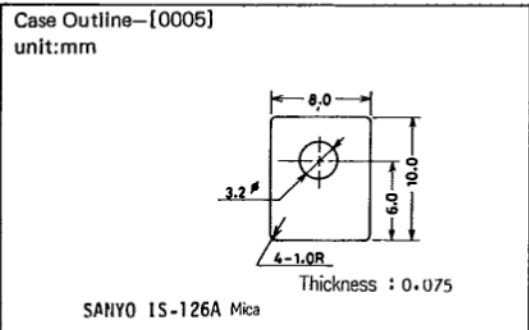
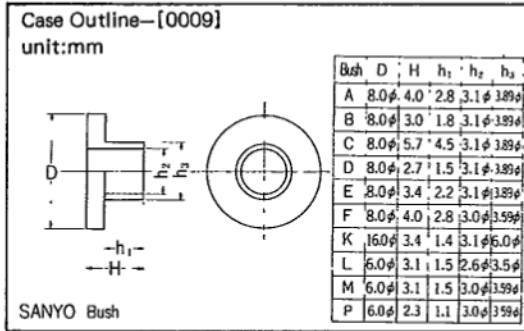
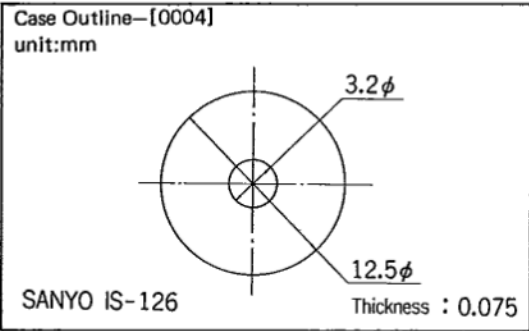
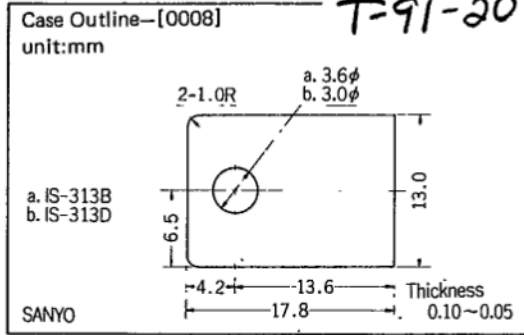
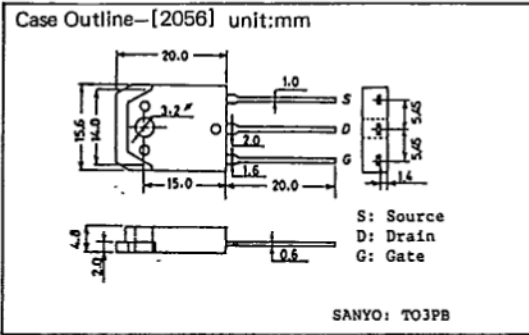

Case Outline-[0013]
unit:mm

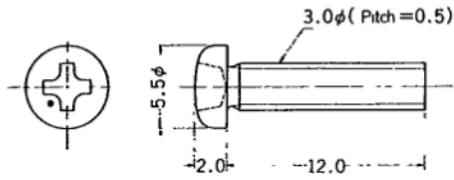

JIS No. B1111 M3X0.5

Case Outline-[0018]
unit:mm

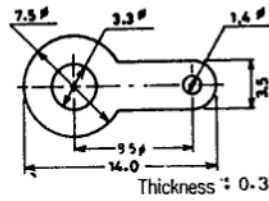

SANYO Lug 1.4

Case Outline-[0014]
unit:mm

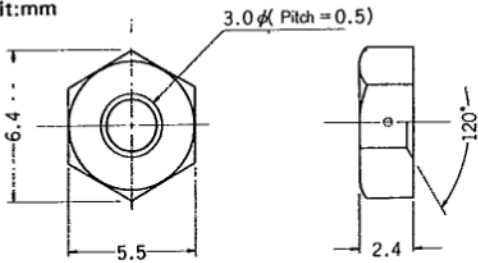

JIS No. B1181 M3X0.5

Case Outline-[0019]
unit:mm

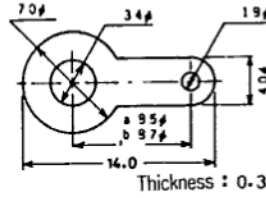

SANYO Lug 1.8φ

Case Outline-[0015]
unit:mm

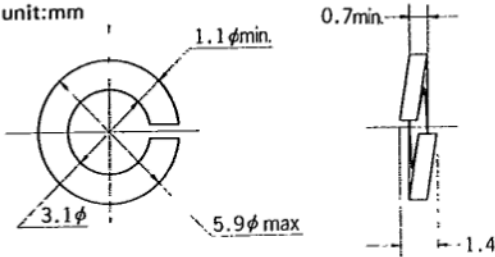

JIS No. B 1251 Spring washer (M3)

Case Outline-[0020]
unit:mm

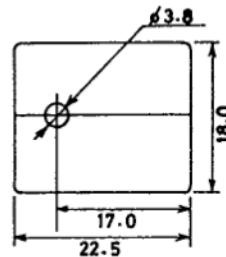

SANYO IS-3MP Mica

Case Outline-[0016]
unit:mm

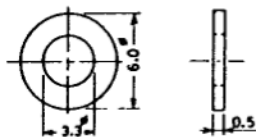

JIS No. B1252 Flat washer

Case Outline-[0021]
unit:mm

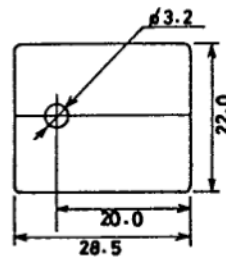

SANYO IS-MPC Mica

Case Outline-[0017]
unit:mm

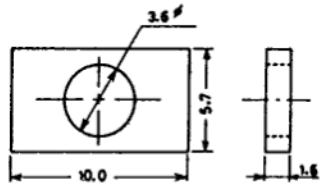

JIS No. G3141 Rectangular washer

Case Outline-[0022]
unit:mm

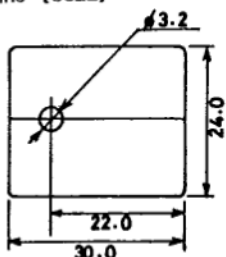

SANYO IS-3PBL Mica