

# **L86** Hardware Design

**GNSS Module Series**

Rev. L86\_Hardware\_Design\_V1.0

Date: 2014-09-04



**Our aim is to provide customers with timely and comprehensive service. For any assistance, please contact our company headquarters:**

**Quectel Wireless Solutions Co., Ltd.**

Office 501, Building 13, No.99, Tianzhou Road, Shanghai, China, 200233

Tel: +86 21 5108 6236

Mail:[info@quectel.com](mailto:info@quectel.com)

**Or our local office, for more information, please visit:**

<http://www.quectel.com/support/salesupport.aspx>

**For technical support, to report documentation errors, please visit:**

<http://www.quectel.com/support/techsupport.aspx>

**GENERAL NOTES**

QUECTEL OFFERS THIS INFORMATION AS A SERVICE TO ITS CUSTOMERS. THE INFORMATION PROVIDED IS BASED UPON CUSTOMERS' REQUIREMENTS. QUECTEL MAKES EVERY EFFORT TO ENSURE THE QUALITY OF THE INFORMATION IT MAKES AVAILABLE. QUECTEL DOES NOT MAKE ANY WARRANTY AS TO THE INFORMATION CONTAINED HEREIN, AND DOES NOT ACCEPT ANY LIABILITY FOR ANY INJURY, LOSS OR DAMAGE OF ANY KIND INCURRED BY USE OF OR RELIANCE UPON THE INFORMATION. ALL INFORMATION SUPPLIED HEREIN IS SUBJECT TO CHANGE WITHOUT PRIOR NOTICE.

**COPYRIGHT**

THIS INFORMATION CONTAINED HERE IS PROPRIETARY TECHNICAL INFORMATION OF QUECTEL CO., LTD. TRANSMITTABLE, REPRODUCTION, DISSEMINATION AND EDITING OF THIS DOCUMENT AS WELL AS UTILIZATION OF THIS CONTENTS ARE FORBIDDEN WITHOUT PERMISSION. OFFENDERS WILL BE HELD LIABLE FOR PAYMENT OF DAMAGES. ALL RIGHTS ARE RESERVED IN THE EVENT OF A PATENT GRANT OR REGISTRATION OF A UTILITY MODEL OR DESIGN.

***Copyright © Quectel Wireless Solutions Co., Ltd. 2014. All rights reserved.***

# About the Document

## History

Revision	Date	Author	Description
V1.0	2014-09-04	King HAO	Initial

Quectel  
Confidential

## Contents

<b>About the Document</b> .....	<b>2</b>
<b>Contents</b> .....	<b>3</b>
<b>Table Index</b> .....	<b>5</b>
<b>Figure Index</b> .....	<b>6</b>
<b>1 Introduction</b> .....	<b>7</b>
<b>2 Description</b> .....	<b>8</b>
2.1. General Description.....	8
2.2. Key Features.....	9
2.3. Block Diagram.....	10
2.4. Evaluation Board.....	11
2.5. Supported Protocols.....	11
<b>3 Application</b> .....	<b>12</b>
3.1. Pin Assignment.....	12
3.2. Pin Definition.....	12
3.3. Power Supply.....	14
3.4. Operating Modes.....	15
3.4.1. Full On Mode.....	16
3.4.2. Standby Mode.....	16
3.4.3. Backup Mode.....	17
3.4.4. Periodic Mode.....	18
3.4.5. AlwaysLocate™ Mode.....	20
3.5. Reset.....	21
3.6. UART Interface.....	22
3.7. EASY Technology.....	24
3.8. Multi-tone AIC.....	24
3.9. LOCUS.....	25
3.10. Antenna Supervisor.....	25
<b>4 Antenna Interface</b> .....	<b>26</b>
4.1. Internal Patch Antenna.....	26
4.1.1. 18.4x18.4x4 Patch Antenna.....	26
4.1.2. PCB Design Guide.....	28
4.2. External Active Antenna.....	29
4.3. Antenna Status Indicator.....	30
<b>5 Electrical, Reliability and Radio Characteristics</b> .....	<b>32</b>
5.1. Absolute Maximum Ratings.....	32
5.2. Operating Conditions.....	33
5.3. Current Consumption.....	33
5.4. Reliability Test.....	34

---

<b>6</b>	<b>Mechanics</b> .....	<b>35</b>
6.1.	Mechanical View of the Module .....	35
6.2.	Bottom Dimension and Recommended Footprint.....	36
6.3.	Top View of the Module.....	37
6.4.	Bottom View of the Module .....	37
<b>7</b>	<b>Manufacturing</b> .....	<b>38</b>
7.1.	Assembly and Soldering .....	38
7.2.	Moisture Sensitivity .....	39
7.3.	ESD Protection.....	39
7.4.	Tape and Reel .....	40
7.5.	Ordering Information .....	40
<b>8</b>	<b>Appendix Reference</b> .....	<b>41</b>

Quectel  
Confidential

## Table Index

TABLE 1: MODULE KEY FEATURES .....	9
TABLE 2: SUPPORTED PROTOCOLS.....	11
TABLE 3: PIN DESCRIPTION .....	12
TABLE 4: MODULE STATES SWITCH .....	15
TABLE 5: DEFAULT CONFIGURATIONS .....	16
TABLE 6: PMTK COMMAND FORMAT .....	18
TABLE 7: STATUS OF THE ANTENNA.....	25
TABLE 8: ANTENNA SPECIFICATION FOR L86 MODULE WITH GROUND PLANE 100MM×60MM .....	26
TABLE 9: RECOMMENDED ACTIVE ANTENNA SPECIFICATION .....	29
TABLE 10: GPTXT - STATUS OF ANTENNA.....	31
TABLE 11: ABSOLUTE MAXIMUM RATINGS .....	32
TABLE 12: THE MODULE POWER SUPPLY RATINGS .....	33
TABLE 13: THE MODULE CURRENT CONSUMPTION .....	33
TABLE 14: RELIABILITY TEST .....	34
TABLE 15: REEL PACKING .....	40
TABLE 16: ORDERING INFORMATION .....	40
TABLE 17: RELATED DOCUMENTS.....	41
TABLE 18: TERMS AND ABBREVIATIONS.....	41

## Figure Index

FIGURE 1: BLOCK DIAGRAM .....	10
FIGURE 2: PIN ASSIGNMENT .....	12
FIGURE 3: INTERNAL POWER CONSTRUCTION.....	14
FIGURE 4: RTC SUPPLY FROM NON-CHARGEABLE BATTERY.....	17
FIGURE 5: REFERENCE CHARGING CIRCUIT FOR CHARGEABLE BATTERY.....	18
FIGURE 6: PERIODIC MODE.....	20
FIGURE 7: ALWAYSLOCATE™ MODE .....	21
FIGURE 8: REFERENCE RESET CIRCUIT USING OC CIRCUIT.....	21
FIGURE 9: RESTART TIMING .....	22
FIGURE 10: CONNECTION OF SERIAL INTERFACES .....	22
FIGURE 11: RS-232 LEVEL SHIFT CIRCUIT.....	23
FIGURE 12: MATCHING MAP OF PATCH ANTENNA .....	27
FIGURE 13: S11 PARAMETERS OF PATCH ANTENNA .....	27
FIGURE 14: L86 MODULE PLACEMENT GUIDE .....	28
FIGURE 15: REFERENCE DESIGN FOR ACTIVE ANTENNA .....	29
FIGURE 16: ACTIVE ANTENNA STATUS DESCRIPTION IN GPTXT .....	31
FIGURE 17: MECHANICAL VIEW (UNIT: MM).....	35
FIGURE 18: BOTTOM DIMENSION (UNIT: MM).....	36
FIGURE 19: FOOTPRINT OF RECOMMENDATION (UNIT: MM).....	36
FIGURE 20: TOP VIEW OF THE MODULE .....	37
FIGURE 21: BOTTOM VIEW OF THE MODULE.....	37
FIGURE 22: RAMP-SOAK-SPIKE-REFLOW OF FURNACE TEMPERATURE .....	38
FIGURE 23: TAPE AND REEL SPECIFICATION.....	40

# 1 Introduction

This document defines and specifies L86 GNSS module. It describes L86 module hardware interfaces and its external application reference circuits, mechanical size and air interface.

This document can help you quickly understand the interface specifications, electrical and mechanical details of L86 module. Other documents such as L86 software application notes and user guider are also provided for you. These documents can ensure you use L86 module to design and set up applications quickly.

Quectel  
Confidential



# 2 Description

## 2.1. General Description

L86 GNSS module with an embedded patch antenna (18.4mm × 18.4mm × 4mm) and LNA brings high performance of MTK positioning engine to the industrial applications. It is able to achieve the industry's highest level of sensitivity, accuracy and TTFF with the lowest power consumption in a small-footprint lead-free package. The embedded flash memory provides capacity for users to store some useful navigation data and allows for future updates.

L86 module combines with many advanced features including EASY, AIC, LOCUS, AlwaysLocate™ and Antenna Supervisor. These features are beneficial to accelerate TTFF, improve sensitivity, save consumption and detect antenna status for GNSS system. The module supports various location, navigation and industrial applications including autonomous GPS, GLONASS, SBAS (including WAAS, EGNOS, MSAS, and GAGAN), QZSS, and AGPS.

L86 module simplifies the device's design and cost because of embedded patch antenna and LNA. Furthermore, L86 module not only supports automatic antenna switching function, which can achieve switching between external active antenna and internal patch antenna, but also supports external active antenna detection and short protection. The detection and notification of different external active antenna status will be shown in the NMEA message including external active antenna connection, open circuit for antenna and antenna short-circuited. So host can query the external active antenna status timely and conveniently.

EASY technology as the key feature of L86 module is one kind of AGPS. Collecting and processing all internal aiding information like GPS time, Ephemeris, Last Position etc., the GNSS module will have a fast TTFF in either Hot or Warm start.

L86 module is a SMD type module with the compact 18.4mm × 18.4mm × 6.45mm form factor, which can be embedded in your applications through the 12-pin pads with 2.54mm pitch. It provides necessary hardware interfaces between the module and main board.

The module is fully ROHS compliant to EU regulation.

## 2.2. Key Features

**Table 1: Module Key Features**

Feature	Implementation
GNSS	<ul style="list-style-type: none"> <li>● GPS+GLONASS</li> </ul>
Power Supply	<ul style="list-style-type: none"> <li>● Supply voltage: 3.0V~4.3V      typical: 3.3V</li> </ul>
Power Consumption	<ul style="list-style-type: none"> <li>● Acquisition: 26mA @VCC=V_BCKP=3.3V (GPS)</li> <li>● Tracking: 22mA @VCC=V_BCKP=3.3V (GPS)</li> <li>● Acquisition: 30mA @VCC=V_BCKP=3.3V (GPS+GLONASS)</li> <li>● Tracking: 26mA @VCC=V_BCKP=3.3V (GPS+GLONASS)</li> <li>● Standby: 1mA @VCC=V_BCKP=3.3V</li> <li>● Backup: 7uA @V_BCKP=3.3V</li> </ul>
Receiver Type	<ul style="list-style-type: none"> <li>● GPS L1 1575.42MHz C/A Code</li> <li>● GLONASS L1 1598.0625~1605.375MHz C/A Code</li> </ul>
Sensitivity	<ul style="list-style-type: none"> <li>● Acquisition: -148dBm</li> <li>● Re-acquisition: -160dBm</li> <li>● Tracking: -165dBm</li> </ul>
TTFB (EASY enabled)	<ul style="list-style-type: none"> <li>● Cold start: 15s typ. @-130dBm</li> <li>● Warm start: 5s typ. @-130dBm</li> <li>● Hot start: 1s typ. @-130dBm</li> </ul>
TTFB (EASY disabled)	<ul style="list-style-type: none"> <li>● Cold start (Autonomous): 35s typ. @-130dBm</li> <li>● Warm start (Autonomous): 30s typ. @-130dBm</li> <li>● Hot start (Autonomous): 1s typ. @-130dBm</li> </ul>
Horizontal Position Accuracy (Autonomous)	<ul style="list-style-type: none"> <li>● &lt;2.5m CEP @-130dBm</li> </ul>
Max Update Rate	<ul style="list-style-type: none"> <li>● Up to 10Hz, 1Hz by default</li> </ul>
Accuracy of 1PPS Signal	<ul style="list-style-type: none"> <li>● Typical accuracy &lt;15ns (Time service is not supported)</li> <li>● Time pulse width 100ms</li> </ul>
Velocity Accuracy	<ul style="list-style-type: none"> <li>● Without aid: 0.1m/s</li> </ul>
Acceleration Accuracy	<ul style="list-style-type: none"> <li>● Without aid: 0.1m/s<sup>2</sup></li> </ul>
Dynamic Performance	<ul style="list-style-type: none"> <li>● Maximum altitude: 18,000m</li> <li>● Maximum velocity: 515m/s Maximum</li> <li>● Acceleration: 4G</li> </ul>
UART Port	<ul style="list-style-type: none"> <li>● UART Port: TXD1 and RXD1</li> <li>● Supports baud rate from 4800bps to 115200bps, 9600bps by default</li> <li>● UART port is used for NMEA output, MTK proprietary commands input and firmware upgrade</li> </ul>

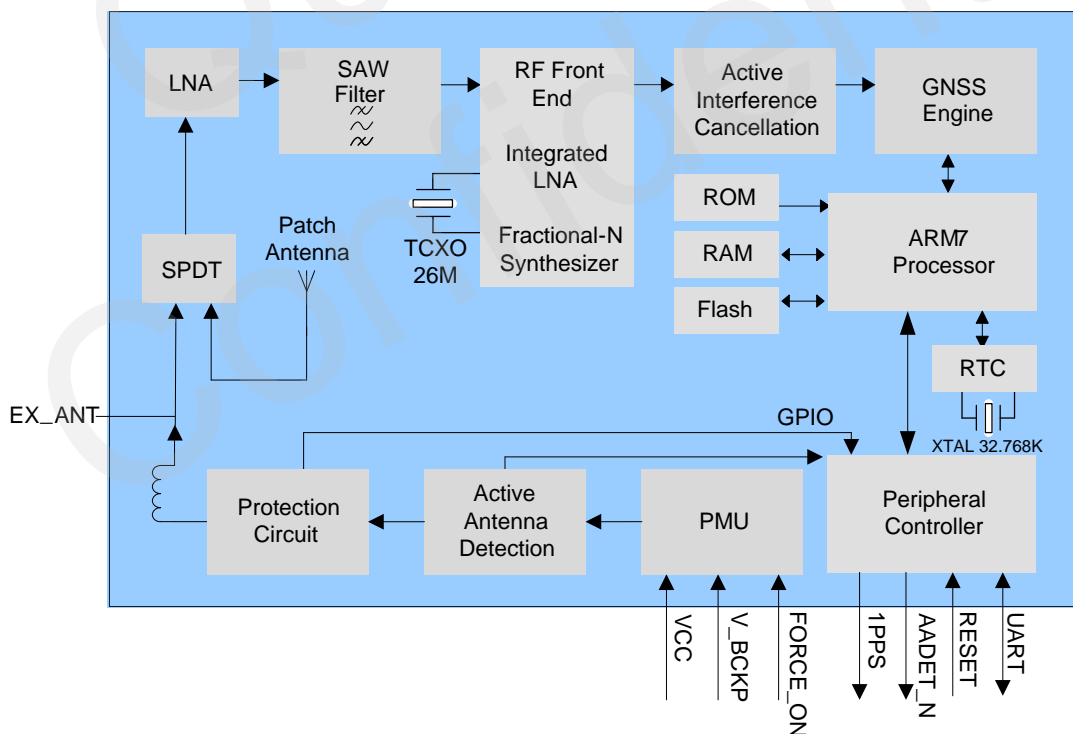
Temperature Range	<ul style="list-style-type: none"> <li>● Normal operation: -40°C ~ +85°C</li> <li>● Storage temperature: -45°C ~ +125°C</li> </ul>
Physical Characteristics	<ul style="list-style-type: none"> <li>● Size: 18.4±0.15 × 18.4±0.15 × 6.45±0.1mm</li> <li>● Weight: Approx. 7.6g</li> </ul>

### NOTES

1. The power consumption is measured in the open sky with internal patch antenna, meanwhile, EASY, AIC and SBAS are enabled.
2. If the external active antenna is used, VCC pin will supply power for external active antenna. The typical additional current consumption is about 10mA @3.3V.
3. The performance of external active antenna is similar to that of internal patch antenna expect for power consumption.

## 2.3. Block Diagram

The following figure shows a block diagram of L86 module. It consists of a single chip GNSS IC which includes RF part and Baseband part, a SPDT, a patch antenna, a LNA, a SAW filter, a TCXO, a crystal oscillator, and short protection and antenna detection circuit for active antenna.



**Figure 1: Block Diagram**

## 2.4. Evaluation Board

In order to help you use L86 module on your applications, Quectel supplies an Evaluation Board (EVB) with micro USB serial cable and other peripherals to test the module.

For more details, please refer to the **document [1]**.

## 2.5. Supported Protocols

**Table 2: Supported Protocols**

Protocol	Type
NMEA	Output, ASCII, 0183, 4.0
PMTK	Input, MTK proprietary protocol

**NOTE**

Please refer to **document [2]** about NMEA standard protocol and MTK proprietary protocol.

# 3 Application

The module is equipped with a 12-pin 2.54mm pitch SMT pad that connects to your application platform. Sub-interfaces included in these pads are described in details in the following chapters.

## 3.1. Pin Assignment



Figure 2: Pin Assignment

## 3.2. Pin Definition

Table 3: Pin Description

Power Supply					
Pin Name	Pin No.	I/O	Description	DC Characteristics	Comment
VCC	4	I	Main power supply	Vmax=4.3V Vmin=3.0V Vnom=3.3V	Supply current of no less than 100mA.

V_BCKP	5	I	Backup power supply	Vmax=4.3V Vmin=1.5V Vnom=3.3V	Supply power for RTC domain. The V_BCKP pin can be directly supplied power by battery or connect it to VCC.
<b>Reset</b>					
Pin Name	Pin No.	I/O	Description	DC Characteristics	Comment
RESET	10	I	System reset	VILmin=-0.3V VILmax=0.7V VIHmin=2.1V VIHmax=3.1V	Low level active. If unused, keep this pin open or connect it to VCC.
<b>UART Port</b>					
Pin Name	Pin No.	I/O	Description	DC Characteristics	Comment
RXD1	1	I	Receive data	VILmin=-0.3V VILmax=0.7V VIHmin=2.1V VIHmax=3.1V	
TXD1	2	O	Transmit data	VOLmax=0.42V VOHmin=2.4V VOHnom=2.8V	
<b>RF Interface</b>					
Pin Name	Pin No.	I/O	Description	DC Characteristics	Comment
EX_ANT	11	I	External active antenna RF input	Characteristic impedance of 50Ω	If unused, keep this pin open.
<b>Other Interfaces</b>					
Pin Name	Pin No.	I/O	Description	DC Characteristics	Comment
1PPS	6	O	One pulse per second	VOLmax=0.42V VOHmin=2.4V VOHnom=2.8V	Synchronized at rising edge, the pulse width is 100ms. If unused, keep this pin open.
FORCE_ON	7	I	Logic high will force module to be waked up from backup mode	VILmin=-0.3V VILmax=0.7V VIHmin=2.1V VIHmax=3.1V	Keep this pin open or pulled low before entering into backup mode. It belongs to RTC domain. If unused, keep this pin open.

AADET_N	8	O	Active antenna detection	VOLmax=0.7V VOHmin=1.3V	If unused, keep this pin open. Refer to <b>chapter 4.3</b> .
---------	---	---	--------------------------	----------------------------	--

### 3.3. Power Supply

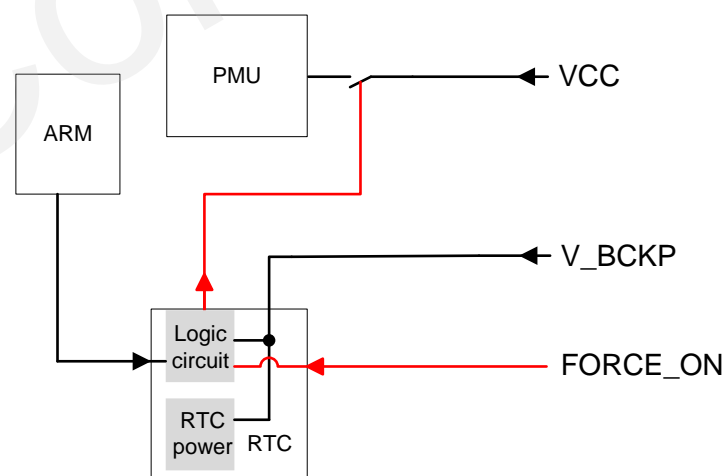
VCC pin supplies power for BB, RF, I/O, LNA, short protection and antenna detection circuit. The load current of VCC varies according to the VCC level, processor load, the number of tracked satellites and the rate of satellite re-acquisition. Using external active antenna will consume an additional current about 10mA from our module. It is important to supply sufficient current and make the power clean and stable. The decouple combination of 10uF and 100nF capacitor is recommended nearby VCC pin.

The V\_BCKP pin supplies power for RTC domain. It should be valid when powering on the module. The voltage of RTC domain ranges from 1.5V to 4.3V. In order to achieve a better TTFF, RTC domain should be valid all the time. It can supply power for SRAM memory in RTC domain which contains all the necessary GNSS information for quick start-up and a small amount of user configuration variables.

The module's internal power construction is shown as below.

VCC supplies power for PMU and V\_BCKP supplies power for RTC domain. FORCE\_ON signal highlighted in red in the following figure belongs to RTC domain and can be used to control the switch on/off. The following action will close and open the switch:

- The switch will be closed by default when VCC & V\_BCKP is supplied power.
- Based on above step, FORCE\_ON open or low and sending PMTK command can open the switch (full on → backup).
- Based on above step, FORCE\_ON logic high can close the switch (backup → full on).



**Figure 3: Internal Power Construction**

**NOTES**

1. VCC does not supply power for RTC domain in L86 module, so the V\_BCKP pin must be powered externally. Furthermore, it is strongly recommended to power V\_BCKP through a backup battery, which can ensure L86 module supports EASY technology and improves TTFF after next restart.
2. Please choose one voltage source without built-in output high speed discharge function, and confirm the voltage drop down curve to keep long output voltage drop down period. Meanwhile, make sure the output voltage drop time is greater than 100ms (from 2.7V to 0.5V).
3. It's strongly recommended to use external LDOs without output discharge function to keep long output voltage drop-down period.
4. Please refer to **document [4]** about GNSS module power supply for more details.

### 3.4. Operating Modes

The table below briefly illustrates the relationship among different operating modes of L86 module.

**Table 4: Module States Switch**

Current Mode	Next Mode				
	Backup	Standby	Full on	Periodic	AlwaysLocate™
Backup	N/A	N/A	Refer to <b>chapter 3.4.3</b>	N/A	N/A
Standby	N/A	N/A	Send any data via UART	N/A	N/A
Full on	Refer to <b>chapter 3.4.3</b>	PMTK161	N/A	Refer to <b>chapter 3.4.4</b>	Refer to <b>chapter 3.4.5</b>
Periodic	N/A	N/A	Refer to <b>chapter 3.4.4</b>	N/A	N/A
AlwaysLocate™	N/A	N/A	Refer to <b>chapter 3.4.5</b>	N/A	N/A

**NOTE**

Please refer to **document [2]** about MTK proprietary protocol for more details.



### 3.4.1. Full On Mode

Full on mode includes tracking mode and acquisition mode. Acquisition mode is defined as the module starts to search satellites, determine visible satellites and coarse carrier frequency and code phase of satellite signals. When the acquisition is completed, it switches to tracking mode automatically. Tracking mode is defined as the module keeps tracking satellites and demodulates the navigation data from the specific satellites.

When the combination of VCC and V\_BCKP is valid, the module will enter into full on mode automatically and follow the default configurations as below. You can refer to **chapter 3.3** about internal power construction to have a good comprehension. You can also use PMTK commands to change the configurations to satisfy your requirements.

**Table 5: Default Configurations**

Item	Configuration	Comment
Baud Rate	9600bps	
Protocol	NMEA	RMC, VTG, GGA, GSA, GSV, GLL and GPTXT (MTK proprietary protocol)
Update Rate	1Hz	
SBAS	Enable	
AIC	Enable	
LOCUS	Disable	
EASY	Enable	EASY will be disabled automatically when update rate exceeds 1Hz.
GNSS	GPS+GLONASS	

### 3.4.2. Standby Mode

Standby mode is a low-power mode. In standby mode, the internal core and I/O power domain are still active, but RF and TCXO are powered off, the module stops satellites search and navigation. UART is still accessible like PMTK commands or any other data, but there is no NMEA messages output.

Sending PMTK command "\$PMTK161,0\*28" will make L86 module enter into standby mode. Sending any data via UART can wake the module up. When the module exits from standby mode, it will use all internal aiding information like GPS time, Ephemeris, Last Position, etc., resulting to a fastest possible TTFF in either Hot or Warm start. The typical standby current consumption in this way is about 1mA @VCC=3.3V.

**NOTE**

When the external active antenna is used, an additional current about 10mA will be consumed because the VCC still supply power for external active antenna in standby mode.

### 3.4.3. Backup Mode

Backup mode is a lower power consumption mode than standby mode. In this mode, the module stops acquiring and tracking satellites. UART is not accessible. But the backed-up memory in RTC domain which contains all the necessary GNSS information for quick start-up and a small amount of user configuration variables is alive. Due to the backed-up memory, EASY technology is available. The typical consumption in this mode can be as low as 7uA.

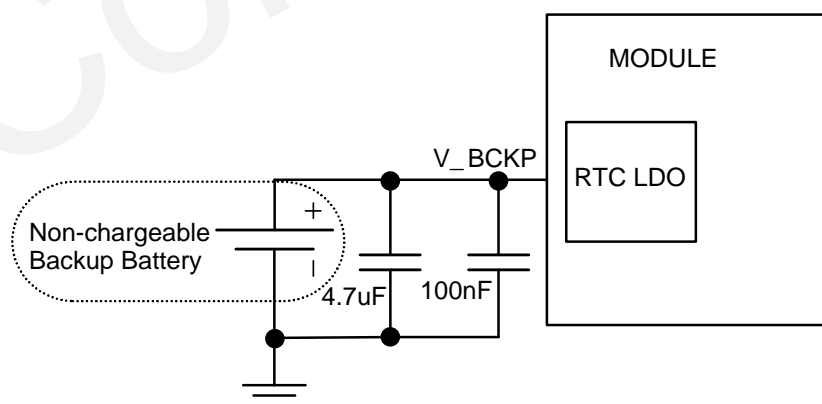
There are two ways to enter into backup mode and back to full on mode:

- Sending command: "\$PMTK225,4\*2F" (the red line opens the switch in Figure 3) to enter into backup mode forever. The only way to wake up the module is pulling the FORCE\_ON high (the red line closes the switch in Figure 3).
- Cutting off VCC and keeping V\_BCKP is alive will make the module enter into backup mode from full on mode. As long as the VCC pin is supplied power, the module will back to full on mode immediately. But this method is not recommended.

**NOTE**

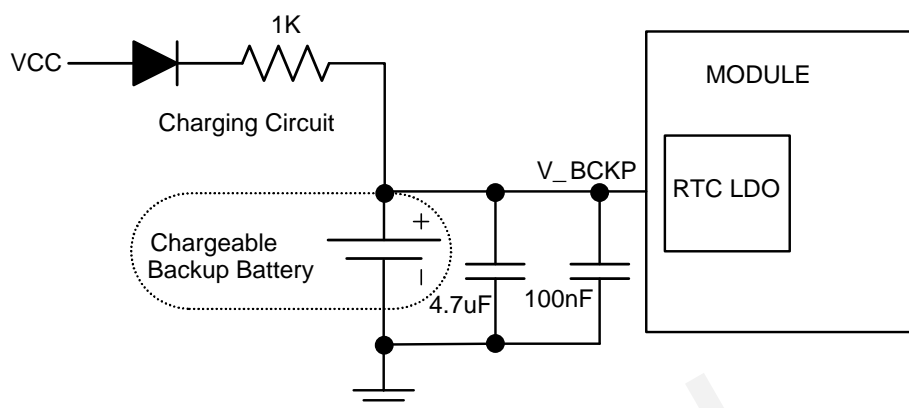
Keep FORCE\_ON pin open or low before entering into backup mode, or it is not available.

The V\_BCKP pin can be directly supplied by an external capacitor or battery (rechargeable or non-chargeable). Please refer to the following figure for RTC backup reference design.



**Figure 4: RTC Supply from Non-chargeable Battery**

The V\_BCKP pin does not support charging function for rechargeable battery. It is necessary to add an external charging circuit for rechargeable battery.



**Figure 5: Reference Charging Circuit for Chargeable Battery**

Coin-type Rechargeable Capacitor from Seiko (<http://www.sii.co.jp/en/>) can be used and Schottky diode from ON Semiconductor (<http://www.onsemi.com/>) is recommended to be used here for its low voltage drop.

### 3.4.4. Periodic Mode

Periodic mode is a power saving mode of L86 module that can control the full on mode and standby/backup mode periodically to reduce power consumption. It contains periodic standby mode and periodic backup mode.

The format of the command which enters into periodic mode is as follows:

**Table 6: PMTK Command Format**

Format:		
\$PMTK225,<Type>,<Run_time>,<Sleep_time>,<2nd_run_time>,<2nd_sleep_time>*<checksum><CR><LF>		
Parameter	Format	Description
Type	Decimal	<b>Type=1</b> for Periodic Backup Mode <b>Type=2</b> for Periodic Standby Mode
Run_time	Decimal	Full on period (ms)
Sleep_time	Decimal	Standby/Backup period (ms)
2nd_run_time	Decimal	Full on period (ms) for extended acquisition in case

		module acquisition fails during the <b>Run_time</b>
<b>2nd_sleep_time</b>	Decimal	Standby/Backup period (ms) for extended sleep in case module acquisition fails during the <b>Run_time</b>
<b>Checksum</b>	Hexadecimal	Hexadecimal checksum

Example:

```
$PMTK225,1,3000,12000,18000,72000*16<CR><LF>
```

```
$PMTK225,2,3000,12000,18000,72000*15<CR><LF>
```

Sending "\$PMTK225,0\*2B" in any time will make the module enter into full on mode from periodic standby mode.

Pulling the FORCE\_ON high and sending "\$PMTK225,0\*2B" immediately will make the module enter into full on mode from periodic backup mode.

Sending "\$PMTK225,0\*2B" in **Run\_time** or **2nd\_run\_time** will also make the module enter into full on mode from periodic backup mode, but it is hard to operate and not recommended.

**NOTE**

Before entering into periodic backup mode, please ensure FORCE\_ON pin is open or low and power supply for V\_BCKP is alive.

The following figure has shown the operation of periodic mode. When you send PMTK command, the module will be in the full on mode firstly. After several minutes, the module will enter into the periodic mode and follow the parameters set by you. When the module fails to fix the position in **run time**, the module will switch to **2nd\_run\_time** and **2nd\_sleep\_time** automatically. As long as the module fixes the position again, the module will return to **Run\_time** and **Sleep\_time**.

Please ensure the module is in the tracking state before entering into periodic mode. Otherwise, the module will have a risk of failure to track the satellites. If GNSS module is located in weak signal environment, it is better to set the longer **2nd\_run\_time** to ensure the success of re-acquisition.

The average current value can be calculated by the following formula:

$$I_{\text{periodic}} = (I_{\text{tracking}} \times T1 + I_{\text{standby/backup}} \times T2) / (T1 + T2) \quad T1: \text{Run\_time}, T2: \text{Sleep\_time}$$

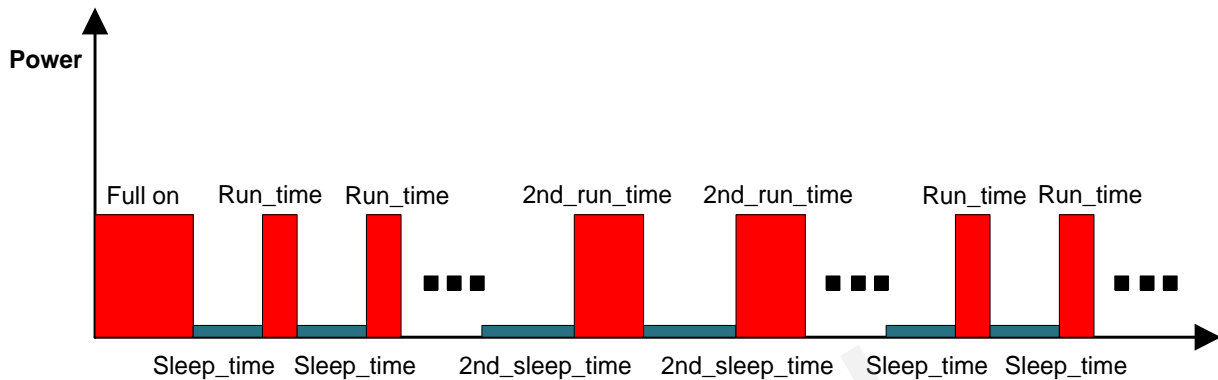
Example:

PMTK225,2,3000,12000,18000,72000\*15 for periodic mode with 3s in tracking mode and 12s in standby mode based on GPS&GLONASS. The average current consumption is calculated as below:

$$I_{\text{periodic}} = (I_{\text{tracking}} \times T1 + I_{\text{standby}} \times T2) / (T1 + T2) = (26 \text{ mA} \times 3\text{s} + 1 \text{ mA} \times 12\text{s}) / (3\text{s} + 12\text{s}) = 6 \text{ (mA)}$$

PMTK225,1,3000,12000,18000,72000\*16 for periodic mode with 3s in tracking mode and 12s in backup mode based on GPS&GLONASS. The average current consumption is calculated as below:

$$I_{\text{periodic}} = (I_{\text{tracking}} \times T1 + I_{\text{backup}} \times T2) / (T1 + T2) = (26 \text{ mA} \times 3\text{s} + 0.007 \text{ mA} \times 12\text{s}) / (3\text{s} + 12\text{s}) \approx 5.2 \text{ (mA)}$$



**Figure 6: Periodic Mode**

### 3.4.5. AlwaysLocate™ Mode

AlwaysLocate™ is an intelligent power saving mode. It contains AlwaysLocate™ backup mode and AlwaysLocate™ standby mode.

AlwaysLocate™ standby mode supports the module to switch automatically between full on mode and standby mode. According to the environmental and motion conditions, the module can adaptively adjust the full on time and standby time to achieve a balance between positioning accuracy and power consumption. Sending "\$PMTK225,8\*23" and the module returning: "\$PMTK001,225,3\*35" means the module accesses AlwaysLocate™ standby mode successfully. It will benefit power saving in this mode. Sending "\$PMTK225,0\*2B" in any time will make the module back to full on mode.

AlwaysLocate™ backup mode is similar to AlwaysLocate™ standby mode. The difference is that AlwaysLocate™ backup mode can switch between full on mode and backup mode automatically. The PMTK command to enter into AlwaysLocate™ backup mode is "\$PMTK225,9\*22". Pulling FORCE\_ON high and sending "\$PMTK225,0\*2B" immediately will make the module back to full on mode.

The positioning accuracy in AlwaysLocate™ mode will be somewhat degraded, especially in high speed. The following picture shows the rough power consumption of L86 module in different daily scenes when AlwaysLocate™ mode is enabled.

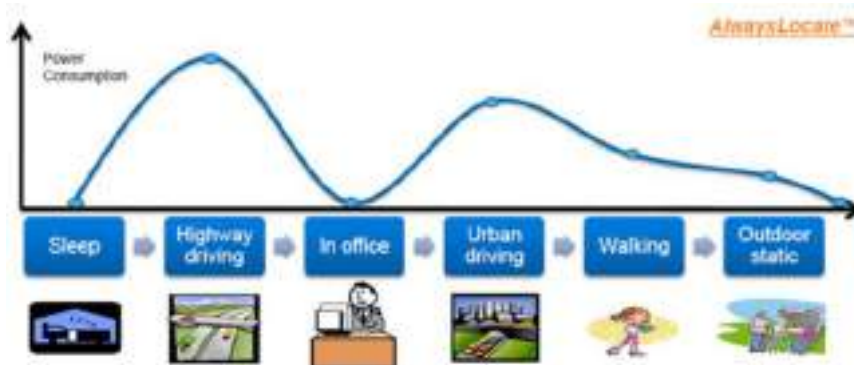


Figure 7: AlwaysLocate™ Mode

Example:

The typical average consumption is about 4.0mA in AlwaysLocate™ standby mode and 3.5mA in AlwaysLocate™ backup mode.

#### NOTES

1. Power consumption is measured in GPS&GLONASS system under outdoor static mode with patch antenna. Using external active antenna will increase the power consumption.
2. Before entering into AlwaysLocate™ backup mode, please ensure FORCE\_ON pin is open or low and power supply for V\_BCKP is alive.

### 3.5. Reset

L86 module can be restarted by driving the RESET to a low level voltage for a certain time and then releasing it. This operation will reset the digital part of the GNSS receiver. Note that Non-Volatile Backup RAM content is not cleared and thus fast TTF is possible. An OC driver circuit shown as below is recommended to control the RESET.

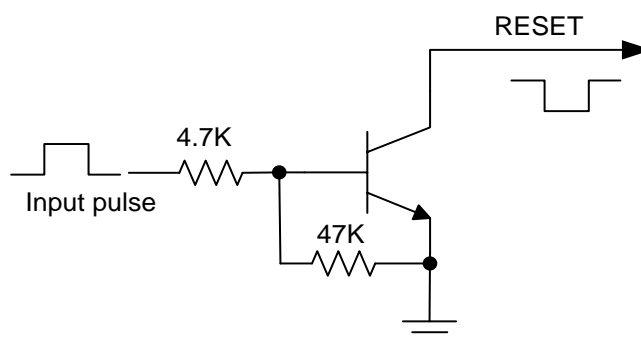
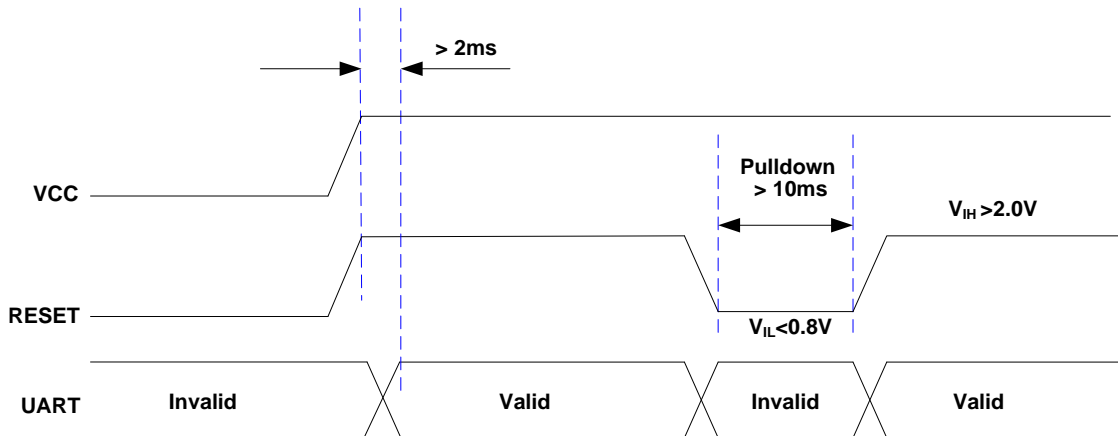


Figure 8: Reference Reset Circuit Using OC Circuit

The restart timing of L86 module has been illustrated bellow.



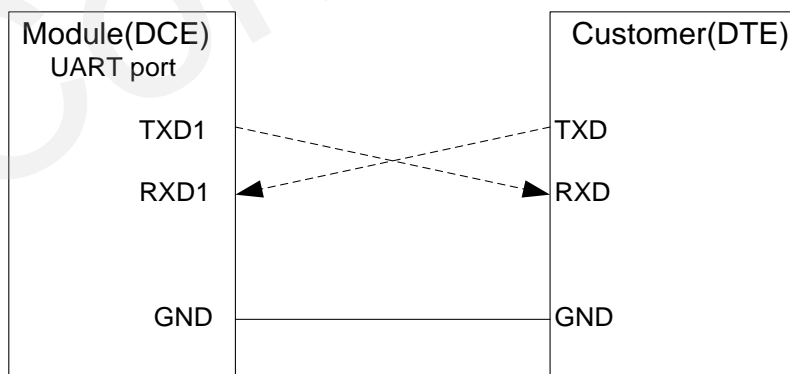
**Figure 9: Restart Timing**

### 3.6. UART Interface

The module provides one universal asynchronous receiver & transmitter serial port. The module is designed as a DCE (Data Communication Equipment), following the traditional DCE-DTE (Data Terminal Equipment) connection. The module and the client (DTE) are connected through the following signals shown as following figure. It supports data baud-rate from 4800bps to 115200bps.

UART port:

- TXD1: Send data to the RXD signal line of DTE.
- RXD1: Receive data from the TXD signal line of DTE.

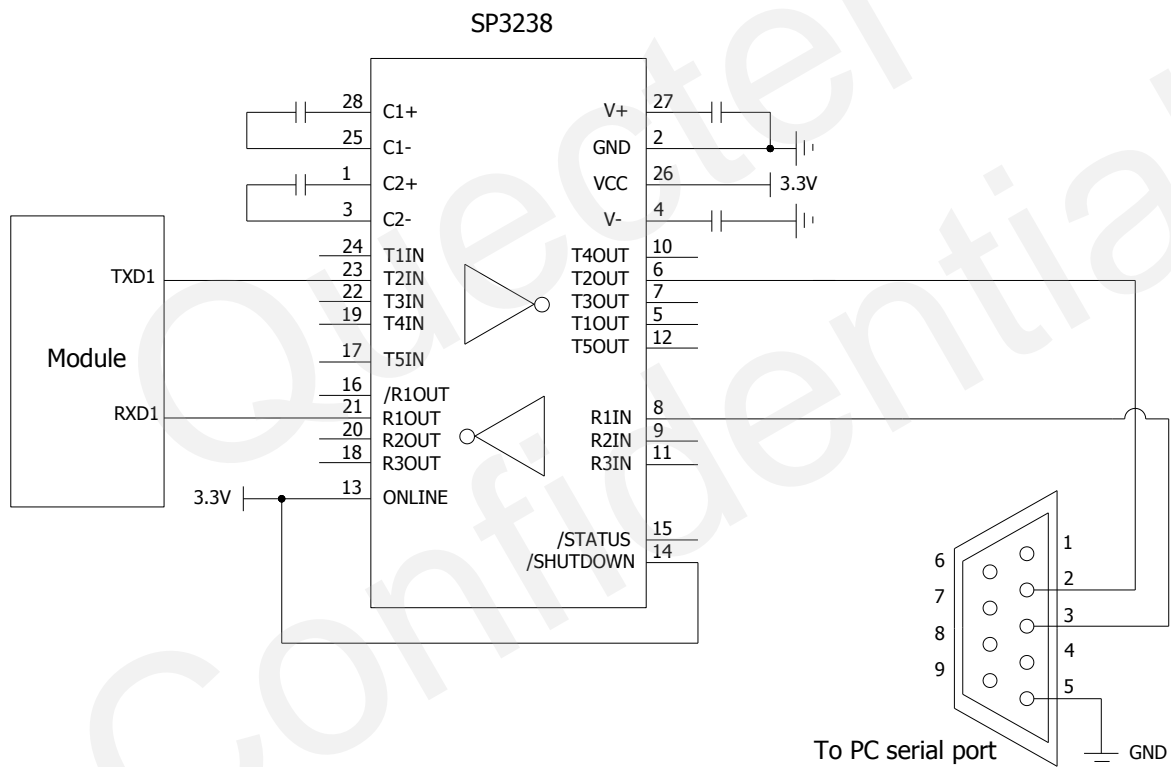


**Figure 10: Connection of Serial Interfaces**

This UART port has the following features:

- UART port can be used for firmware upgrade, NMEA output and PMTK proprietary commands input.
- The default output NMEA type setting is **RMC, VTG, GGA, GSA, GSV, GLL and GPTXT (MTK proprietary protocol)**.
- UART port supports the following data rates:  
4800, 9600, 14400, 19200, 38400, 57600, 115200.  
**The default setting is 9600bps, 8 bits, no parity bit, 1 stop bit.**
- Hardware flow control and synchronous operation are not supported.

The UART port does not support the RS-232 level but only CMOS level. If the module's UART port is connected to the UART port of a computer, it is necessary to add a level shift circuit between the module and the computer. Please refer to the following figure.



**Figure 11: RS-232 Level Shift Circuit**

**NOTE**

As GNSS module outputs more data than single GPS system. The default output NMEA types running in 4800 baud rate and 1Hz update rate will lose some data. The solution to avoid losing data in 4800 baud rate and 1Hz update rate is to decrease the output NMEA types. 9600 baud rate is enough to transmit GNSS NMEA in default settings and it is recommended.



### 3.7. EASY Technology

EASY technology works as embedded software which can accelerate TTFF by predicting satellite navigation messages from received ephemeris. The GNSS engine will calculate and predict orbit information automatically up to 3 days after first receiving the broadcast ephemeris, and saving the predicted information into the internal memory. GNSS engine will use this information for positioning if no enough information from satellites, so the function will be helpful for positioning and TTFF improvement.

The EASY function can reduce TTFF to 5s for warm start. In this case, RTC domain should be valid. In order to get enough broadcast ephemeris information from GPS satellites, the GNSS module should receive the information for at least 5 minutes in a good signal condition after fixing the position.

EASY function is enabled by default. The command “\$PMTK869,1,0\*34” can be used to disable EASY. For more details, please refer to the **document [2]**.

### 3.8. Multi-tone AIC

L86 module provides an advanced technology called multi-tone AIC (Active Interference Cancellation) to reject RF interference which comes from other active components on the main board.

Up to 12 multi-tone AIC embedded in the module can provide effective narrow-band interference and jamming elimination. The GNSS signal could be recovered from the jammed signal, which can ensure better navigation quality. AIC is enabled by default, closing it will save about 1mA @VCC=3.3V consumption. The following commands can be used to set AIC.

Enable AIC function: “\$PMTK 286,1\*23”.

Disable AIC function: “\$PMTK 286,0\*22”.

### 3.9. LOCUS

L86 module supports the embedded logger function called LOCUS. It can log position information to the internal flash memory automatically when this function is enabled by sending PMTK command "\$PMTK185, 0\*22". Due to this function, the host can go to sleep to save power consumption and do not need to receive the NMEA information all the time. The module can provide a log capacity of more than 16 hours.

The detail procedures of this function are illustrated as bellow:

- The module has fixed the position (only 3D\_fixed is available);
- Sending PMTK command "\$PMTK184,1\*22" to erase internal flash;
- Sending PMTK command "\$PMTK185,0\*22" to start log;
- Module logs the basic information (UTC time, latitude, longitude and height) every 15 seconds to internal flash memory;
- Stop logging the information by sending "\$PMTK185,1\*23";
- Host can get the data from the module via UART by sending "\$PMTK622,1\*29".

The raw data which host gets has to be parsed via LOCUS parser code provided by Quectel. For more details, please contact Quectel technical support.

### 3.10. Antenna Supervisor

Antenna Supervisor is designed to detect different external active antenna status including external active antenna connection, open circuit for antenna and antenna short-circuited, and then notify the module. The detections and notifications of external active antenna are listed in the following table.

**Table 7: Status of the Antenna**

Status of the Antenna	EXT/Patch	NMEA Message
External Active Antenna is not Inserted	Patch	OPEN
External Active Antenna is Inserted and Worked Normally	EXT	OK
External Active Antenna is Inserted but Short-circuited	Patch	SHORT

# 4 Antenna Interface

L86 GNSS module supports both GPS and GLONASS systems. The LNA is embedded for better performance. It is an ultra-compact module with embedded 18.4 × 18.4 × 4.0mm patch antenna, in addition, L86 module can also support external active antenna, and the RF signal is obtained from the EX\_ANT pin. Both internal patch signal and external active antenna signal are intelligently switched through SPDT.

## 4.1. Internal Patch Antenna

### 4.1.1. 18.4×18.4×4 Patch Antenna

The quality of the embedded GNSS antenna is crucial to the overall sensitivity of the GNSS system. L86 module offers an on-module patch antenna. An 18.4 × 18.4 × 4.0mm high-performance patch antenna is chosen for reducing product size. This antenna is specially designed for satellite reception applications. And it has excellent stability and sensitivity to consistently provide high signal reception efficiency. The specification of the antenna used by L86 module is described in following table.

**Table 8: Antenna Specification for L86 Module with Ground Plane 100mm×60mm**

Antenna Type	Parameter	Specification	Notes
Patch Antenna	Size	18.4 × 18.4 × 4.0mm	
	Range of receiving Frequency	GPS: 1575.42MHz±1.023MHz GLONASS: 1598.0625~1605.375MHz	
	Impedence	50 Ohm	
	Band Width	10MHz minimum	Return Loss ≤ -10dB
	Frequency Temperature Coefficient (TF)	0±20ppm/ °C	-40°C -85°C
	Polarization	RHCP	Right Hand Circular Polarization
	Gain at Zenith	4.0dBi typ.	Centre frequency
	VSWR	1.5 max	

The test result of the antenna is shown as the following figure. This embedded GNSS antenna provides good radiation efficiency, right hand circular polarization and optimized radiation pattern. The antenna is insensitive to surroundings and has high tolerance against frequency shifts.



Figure 12: Matching Map of Patch Antenna

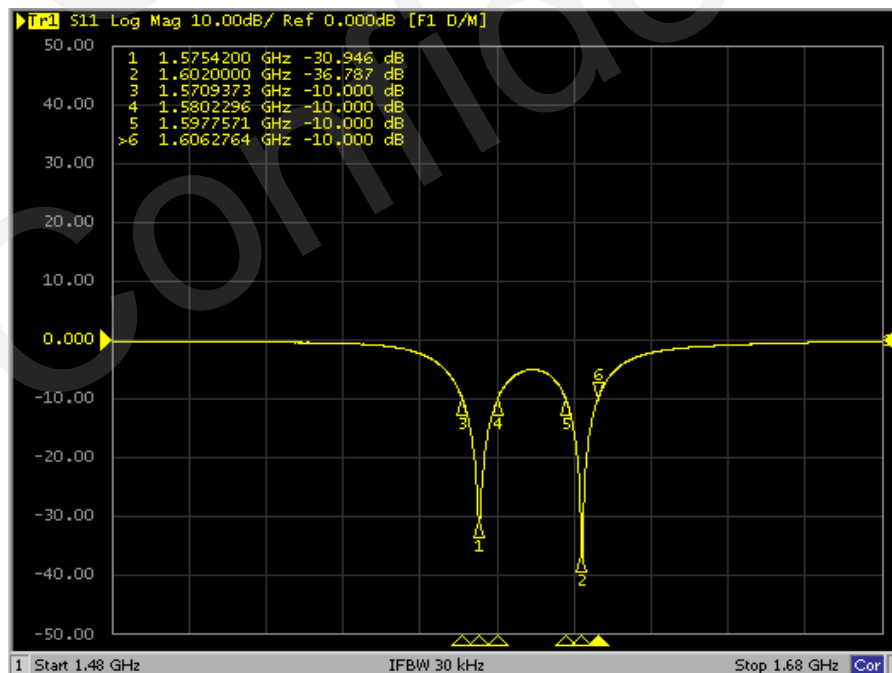


Figure 13: S11 Parameters of Patch Antenna

### 4.1.2. PCB Design Guide

Radiation characteristics of antenna depend on various factors, such as the size and shape of the PCB, the dielectric constant of components nearby. For the best performance, it is recommended to follow these rules listed as below.

Keep at least 10mm away from the nearest edge of the mother board. It is better for L86 module to be placed in the center of the mother board.

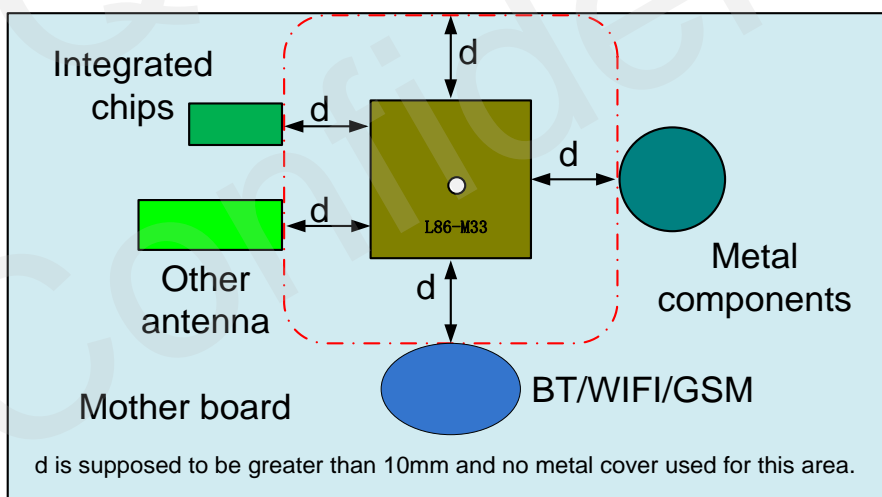
Keep enough distance between L86 module antenna and tall components, the height of which is more than 6mm, and the minimum distance ( $d$ ) is 10mm.

Put L86 module on the top of the main PCB, which can guarantee antenna to face to open sky and achieve good receiving performance during operation.

Device enclosure should be made of non-metal materials especially around antenna area. The minimum distance between antenna and enclosure is 1mm.

It is recommended that the mother board is bigger than 80mm×40mm for the better performance. And pour ground copper on the whole mother board.

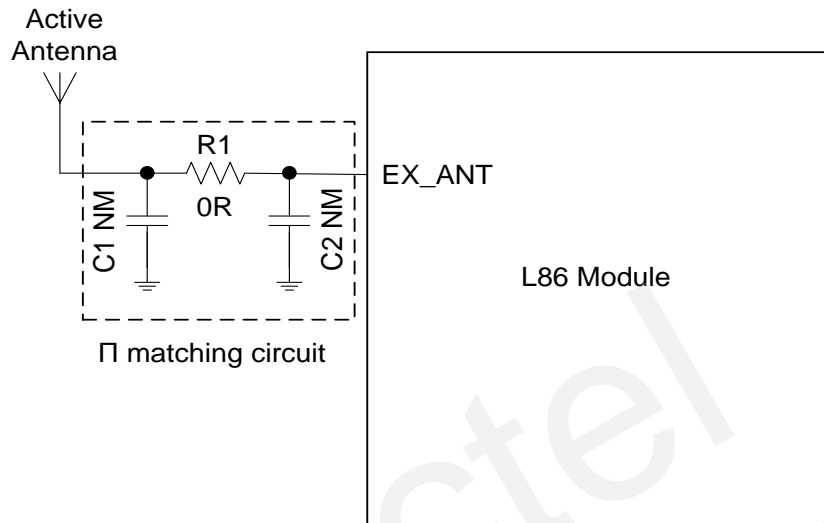
Other antennas such as BT\WIFI\GSM should be kept minimum 10mm distance far away from the embedded patch antenna in L86 module.



**Figure 14: L86 Module Placement Guide**

## 4.2. External Active Antenna

The following figure is a typical reference design with active antenna. In this mode, DC on the EX\_ANT pin is powered by VCC and supplies power to the external active antenna.



**Figure 15: Reference Design for Active Antenna**

C1, R1, C2 are reserved matching circuit for antenna impedance modification. By default, C1 and C2 are not mounted, R1 is 0 ohm. In this mode, R1 must not be capacitance, as current will stream through R1 to the active antenna. C1 and C2 must not be inductance or resistance to avoid short circuit.

The impedance of RF trace line in main PCB should be controlled by 50 Ohm, and the length should be kept as short as possible.

**Table 9: Recommended Active Antenna Specification**

Antenna Type	Specification
Active Antenna	GPS frequency: 1575.42±2MHz GLONASS frequency: 1602±4MHz VSWR: <2 (Typ.) Polarization: RHCP or Linear Noise figure: <1.5dB Gain (antenna): >-2dBi Gain (embedded LNA): 20dB (Typ.) Total gain: >18dBi (Typ.)

**NOTE**

In order to ensure the short protection function can work effectively, please select a DC-open (DC-impedance between the SMA's inner signal needle and outside ground) GNSS active antenna. You can measure the DC-impedance with a common and simple multimeter on few samples, and the value is generally in M ohm level.

### 4.3. Antenna Status Indicator

L86 module supports automatic antenna switching function. The GPTXT sentence can be used to identify the status of external active antenna.

If **ANTSTATUS=OPEN**, it means external active antenna is not connected or has poor contact with antenna feeding point and the internal antenna is used.

If **ANTSTATUS=OK**, it means external active antenna is connected and the module will use external active antenna.

If **ANTSTATUS=SHORT**, it means active antenna is short circuited and the internal patch antenna will be used automatically.

**NOTE**

Because antenna short protection is enabled by default, L86 module will switch to embedded patch antenna automatically in case that external active antenna is short-circuited, which will avoid L86 module from damage. Meanwhile, you need to check the external active antenna.

Example:  
“OPEN” is displayed in the GPTXT sentence as below:

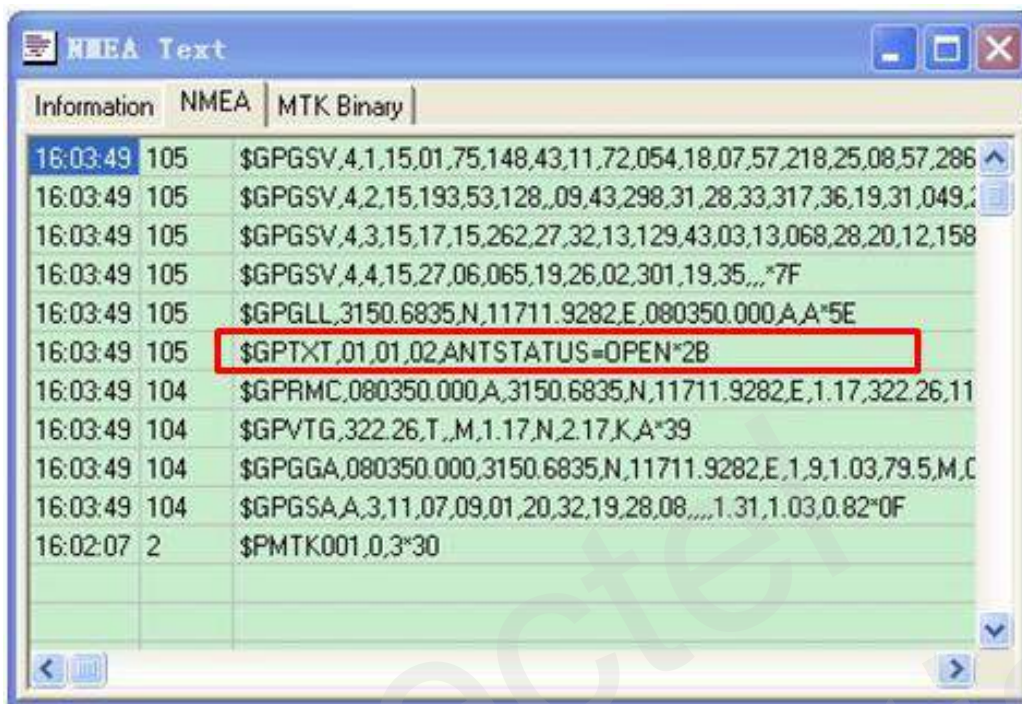


Figure 16: Active Antenna Status Description in GPTXT

Table 10: GPTXT - Status of Antenna

GPTXT Display	Ext Active Antenna Status	Inner Patch Antenna Status	Attention
OPEN	Unused	Working	You need to check the external active antenna status if the active antenna is used.
OK	Working	Unused	
SHORT	Short	Working	Please check the external active antenna

The pin “AADET\_N” also can be used to indicate the status of active antenna. When active antenna is not connected to EX\_ANT or has poor contact with antenna feeding point, AADET\_N will keep a high level to indicate the absence of the active antenna. AADET\_N will change to a low level when active antenna is connected well.

**NOTE**

Active antenna is ONLY available when the voltage of AADET\_N ≤ 0.7 V.



# 5 Electrical, Reliability and Radio Characteristics

## 5.1. Absolute Maximum Ratings

Absolute maximum ratings for power supply and voltage on digital pins of the module are listed in the following table.

**Table 11: Absolute Maximum Ratings**

Parameter	Min.	Max.	Unit
Power Supply Voltage (VCC)	-0.3	4.5	V
Backup Battery Voltage (V_BCKP)	-0.3	4.5	V
Input Voltage at Digital Pins	-0.3	3.6	V
Input Power at EX_ANT		15	dBm
Storage Temperature	-45	125	°C

**NOTE**

Stressing the device beyond the “Absolute Maximum Ratings” may cause permanent damage. These are stress ratings only. The product is not protected against over voltage or reversed voltage. If necessary, voltage spikes exceeding the power supply voltage specification, given in table above, must be limited to values within the specified boundaries by using appropriate protection diodes.

## 5.2. Operating Conditions

**Table 12: The Module Power Supply Ratings**

Parameter	Description	Conditions	Min.	Typ.	Max.	Unit
VCC	Supply voltage	Voltage must stay within the min/max values, including voltage drop, ripple, and spikes.	3.0	3.3	4.3	V
I <sub>VCCP</sub>	Peak supply current	VCC=3.3V			100	mA
V_BCKP	Backup voltage supply		1.5	3.3	4.3	V
TOPR	Normal operating temperature		-40	25	85	°C

### NOTES

1. The figure I<sub>VCCP</sub> can be used to determine the maximum current capability of power supply.
2. Operation beyond the "Operating Conditions" is not recommended and extended exposure beyond the "Operating Conditions" may affect the device's reliability.

## 5.3. Current Consumption

The values for current consumption are shown in the following table.

**Table 13: The Module Current Consumption**

Parameter	Conditions	Min.	Typ.	Max.	Unit
I <sub>VCC</sub> @Acquisition	VCC=V_BCKP=3.3V (GPS)		26		mA
I <sub>VCC</sub> @Tracking	VCC=V_BCKP=3.3V (GPS)		22		mA
I <sub>VCC</sub> @Acquisition	VCC=V_BCKP=3.3V (GPS+GLONASS)		30		mA
I <sub>VCC</sub> @Tracking	VCC=V_BCKP=3.3V (GPS+GLONASS)		26		mA
I <sub>VCC</sub> @Standby	VCC=V_BCKP=3.3V		1.0		mA
I <sub>BCKP</sub> @Backup	V_BCKP=3.3V		7		uA

**NOTE**

The tracking current is tested in the following conditions:

- For Cold Start, 10 minutes after First Fix.
- For Hot Start, 15 seconds after First Fix.

## 5.4. Reliability Test

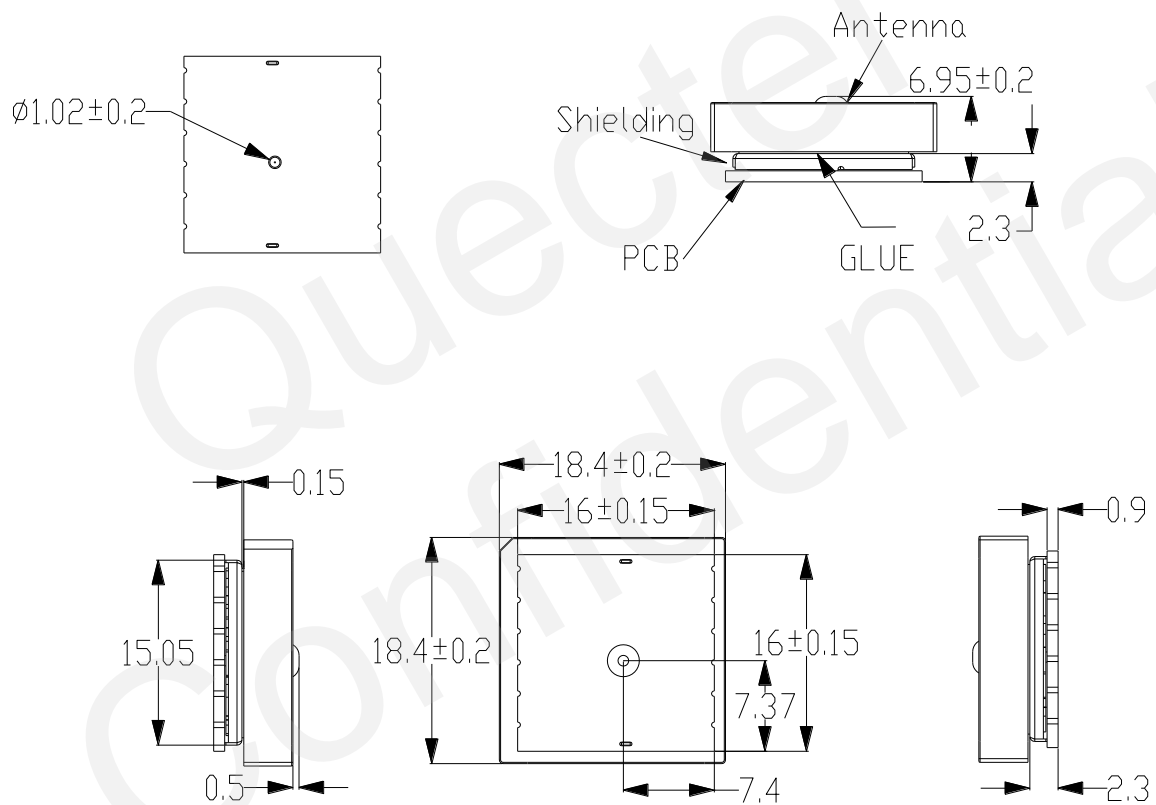
**Table 14: Reliability Test**

Test Item	Conditions	Standard
Thermal Shock	-30°C...+80°C, 144 cycles	GB/T 2423.22-2002 Test Na IEC 68-2-14 Na
Damp Heat, Cyclic	+55°C; >90% Rh 6 cycles for 144 hours	IEC 68-2-30 Db Test
Vibration Shock	5~20Hz, 0.96m2/s3; 20~500Hz, 0.96m2/s3-3dB/oct, 1hour/axis; no function	2423.13-1997 Test Fdb IEC 68-2-36 Fdb Test
Heat Test	85°C, 2 hours, operational	GB/T 2423.1-2001 Ab IEC 68-2-1 Test
Cold Test	-40°C, 2 hours, operational	GB/T 2423.1-2001 Ab IEC 68-2-1 Test
Heat Soak	90°C, 72 hours, non-operational	GB/T 2423.2-2001 Bb IEC 68-2-2 Test B
Cold Soak	-45°C, 72 hours, non-operational	GB/T 2423.1-2001 A IEC 68-2-1 Test

# 6 Mechanics

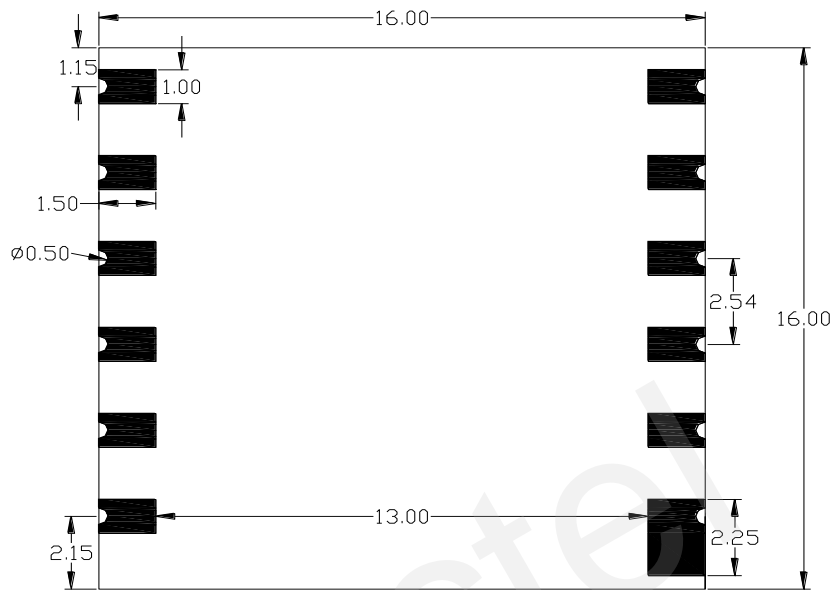
This chapter describes the mechanical dimensions of the module.

## 6.1. Mechanical View of the Module

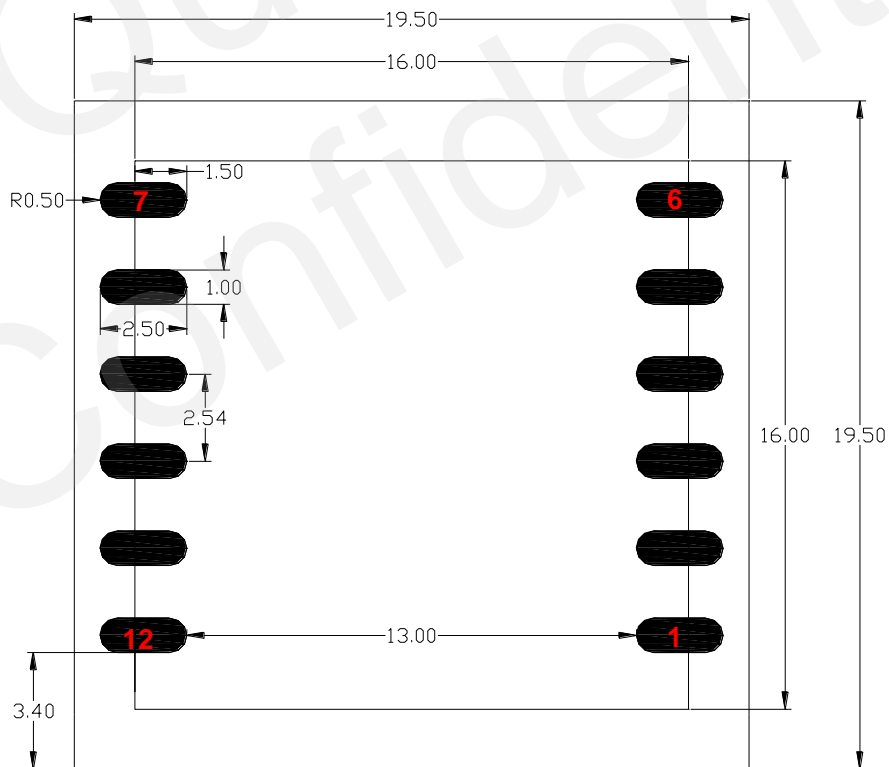


**Figure 17: Mechanical View (Unit: mm)**

## 6.2. Bottom Dimension and Recommended Footprint



**Figure 18: Bottom Dimension (Unit: mm)**



**Figure 19: Footprint of Recommendation (Unit: mm)**

**NOTE**

For easy maintenance, please keep a distance of no less than 3mm between the module and other components in host board.

### 6.3. Top View of the Module



Figure 20: Top View of the Module

### 6.4. Bottom View of the Module

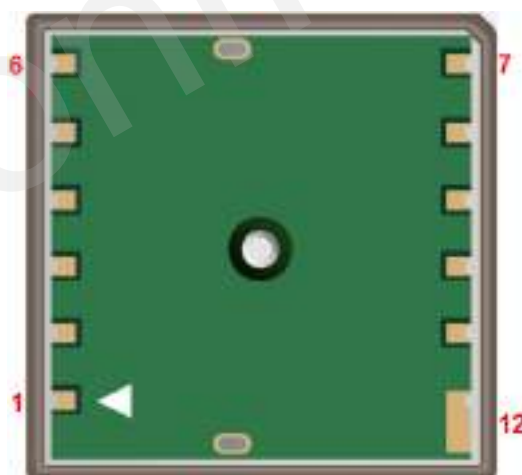


Figure 21: Bottom View of the Module

# 7 Manufacturing

## 7.1. Assembly and Soldering

L86 module is intended for SMT assembly and soldering in a Pb-free reflow process on the top side of the PCB. It is suggested that the minimum height of solder paste stencil is 100um to ensure sufficient solder volume. Pad openings of paste mask can be increased to ensure proper soldering and solder wetting over pads. It is suggested that peak reflow temperature is 235~245°C (for SnAg3.0Cu0.5 alloy). Absolute max reflow temperature is 260°C. To avoid damage to the module when it is repeatedly heated, it is suggested that the module should be mounted after the first panel has been reflowed. The following picture is the actual diagram which we have operated.

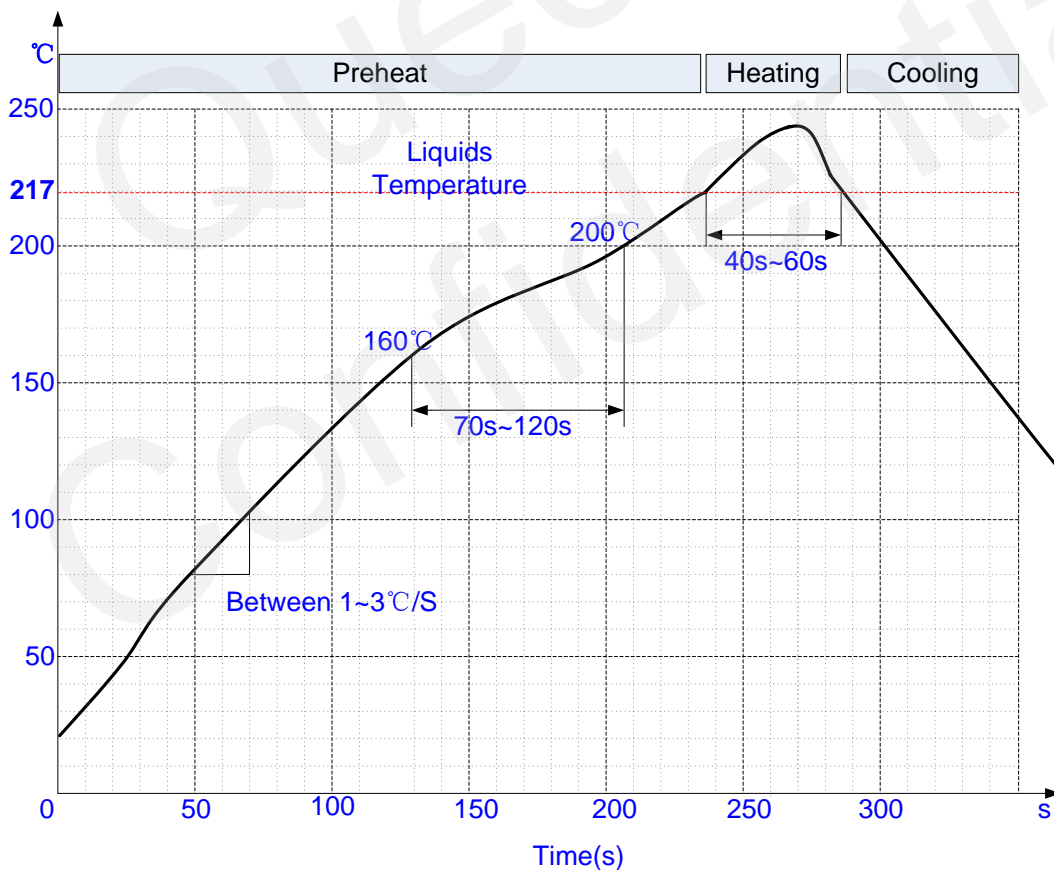


Figure 22: Ramp-soak-spike-reflow of Furnace Temperature

## 7.2. Moisture Sensitivity

L86 module is sensitivity to moisture absorption. To prevent L86 module from permanent damage during reflow soldering, baking before reflow is required in following cases:

- Humidity indicator card: At least one circular indicator is no longer blue.
- The seal is opened and the module is exposed to excessive humidity.

L86 module should be baked for 192 hours at temperature  $40^{\circ}\text{C} +5^{\circ}\text{C} /-0^{\circ}\text{C}$  and  $<5\%$  RH in low-temperature containers, or 24 hours at temperature  $125^{\circ}\text{C} \pm 5^{\circ}\text{C}$  in high-temperature containers. Care should be taken that plastic tape is not heat resistant. L86 module should be taken out before preheating, otherwise, the tape maybe damaged by high-temperature heating.

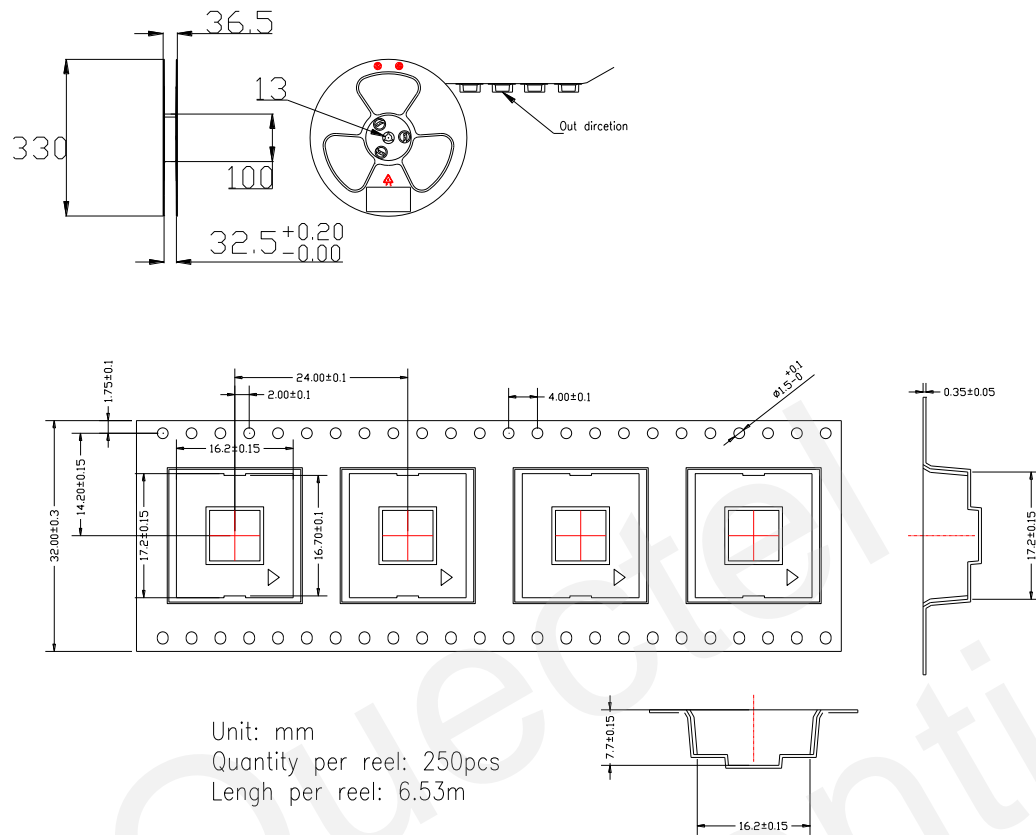
## 7.3. ESD Protection

L86 module is an ESD sensitive device. ESD protection precautions should be emphasized. Proper ESD handing and packaging procedures must be applied throughout the processing, handling and operation of any application. Please note the following measures are good for ESD protection when L86 module is handled.

- Unless there is a galvanic coupling between the local GND and the PCB GND, then the first point of contact shall always be between the local GND and PCB GND when handling the PCB.
- Before mounting with the RF\_IN pad, please make sure the GND of the module has been connected.
- Do not contact any charged capacitors and materials which can easily develop or store charges (such as patch antenna, coax cable, soldering iron) when handling with the RF\_IN pad.
- To prevent electrostatic discharge from the RF input, please do not touch any exposed area of the mounted patch antenna.
- Make sure to use an ESD safe soldering iron (tip) when soldering the RF\_IN pin.



## 7.4. Tape and Reel



**Figure 23: Tape and Reel Specification**

**Table 15: Reel Packing**

Model Name	MOQ for MP	Minimum Package: 250pcs	Minimum Packagex4=1000pcs
L86	250pcs	Size: 370mm × 350mm × 56mm N.W: 1.5kg G.W: 2.25kg	Size: 380mm × 250mm × 365mm N.W: 6.1kg G.W: 9.4kg

## 7.5. Ordering Information

**Table 16: Ordering Information**

Model Name	Ordering Code
L86	L86-M33

# 8 Appendix Reference

**Table 17: Related Documents**

SN	Document Name	Remark
[1]	Quectel_L86_EVB_User Guide	L86 EVB User Guide
[2]	Quectel_L86_GNSS_Protocol_Specification	L86 GNSS Protocol Specification
[3]	Quectel_L80&L86_Reference_Design	L80&L86 Reference Design
[4]	Quectel_GNSS_Modules_with_MTK_Engine_AN	GNSS Modules with MTK Engine Application Note

**Table 18: Terms and Abbreviations**

Abbreviation	Description
AGPS	Assisted GPS
AIC	Active Interference Cancellation
CEP	Circular Error Probable
DGPS	Differential GPS
EASY	Embedded Assist System
EGNOS	European Geostationary Navigation Overlay Service
EPO	Extended Prediction Orbit
ESD	Electrostatic Discharge
GPS	Global Positioning System
GNSS	Global Navigation Satellite System
GGA	GPS Fix Data
GLL	Geographic Position – Latitude/Longitude

GLONASS	Global Navigation Satellite System
GSA	GNSS DOP and Active Satellites
GSV	GNSS Satellites in View
HDOP	Horizontal Dilution of Precision
I/O	Input/Output
Kbps	Kilo Bits Per Second
LNA	Low Noise Amplifier
MSAS	Multi-Functional Satellite Augmentation System
MOQ	Minimum Order Quantity
NMEA	National Marine Electronics Association
PDOP	Position Dilution of Precision
PMTK	MTK Proprietary Protocol
PPS	Pulse Per Second
PRN	Pseudo Random Noise Code
QZSS	Quasi-Zenith Satellite System
RHCP	Right Hand Circular Polarization
RMC	Recommended Minimum Specific GNSS Data
SBAS	Satellite-based Augmentation System
SAW	Surface Acoustic Wave
SPDT	Single-Pole Double-Throw
TTF	Time To First Fix
UART	Universal Asynchronous Receiver & Transmitter
VDOP	Vertical Dilution of Precision
VTG	Course over Ground and Ground Speed, Horizontal Course and Horizontal Velocity
WAAS	Wide Area Augmentation System
Inom	Nominal Current

---

I <sub>max</sub>	Maximum Load Current
V <sub>max</sub>	Maximum Voltage Value
V <sub>nom</sub>	Nominal Voltage Value
V <sub>min</sub>	Minimum Voltage Value
V <sub>IHmax</sub>	Maximum Input High Level Voltage Value
V <sub>IHmin</sub>	Minimum Input High Level Voltage Value
V <sub>ILmax</sub>	Maximum Input Low Level Voltage Value
V <sub>ILmin</sub>	Minimum Input Low Level Voltage Value
V <sub>Imax</sub>	Absolute Maximum Input Voltage Value
V <sub>Imin</sub>	Absolute Minimum Input Voltage Value
V <sub>OHmax</sub>	Maximum Output High Level Voltage Value
V <sub>OHmin</sub>	Minimum Output High Level Voltage Value
V <sub>OLmax</sub>	Maximum Output Low Level Voltage Value
V <sub>OLmin</sub>	Minimum Output Low Level Voltage Value

---