

## Miniature High Power Relay

### SLI-Series

#### Features

- Miniature relay with high switching capability : 30A.
- Contact form : Form A, Form B or 1Form C.
- Special type of 4000VAC dielectric strength and 6000V surge voltage (1.2/50 uS) between coil and contact available.
- Sealed type available.
- Satisfy IEC60335-1 product is available.
- Satisfy IEC60079-15 product is available.



#### Safety Approval

UL , C-UL File No. : E190598

TUV File No. : R50143450

CQC File No. : CQC02001002109

VDE File No. : 40036707

#### Contact Capacity

Model	SLI-DM	SLI-DB	SLI-D
Nominal switching capacity (res. load)	30A 250VAC	15A 250VAC	20A/10A 250VAC
Max. switching current	30A	20A	20A
Max. switching voltage	250VAC	250VAC	250VAC
Max. switching power	7,500VA	5,000VA	5,000VA

#### Characteristic Data

Contact material	Silver alloy	
Initial contact resistance (at 6VDC 1A)	50mΩ Max.(1A 6VDC)	
Operate time (at nominal volt.)	15msec. Max.(no diode)	
Release time (at nominal volt.)	10msec. Max.(no diode)	
Initial insulation resistance	100MΩ Min.(DC500V)	
Initial dielectric strength	Between open contacts : AC1,500V , 50/60Hz 1min.	
	Between coil and contact : AC2,500V , 50/60Hz 1min.(AC4KV available)	
Vibration resistance	Functional	10 ~ 55Hz at double amplitude of 1.5 mm
	Destructive	10 ~ 55Hz at double amplitude of 1.5 mm
Shock resistance	Functional	10G Min.
	Destructive	100G Min.
Endurance (operations)	Mechanical (at 10,800 ops./h)	10,000,000 cycles(at room temperature)
	Electrical (at 360 ops./h)	100,000 cycles(at room temperature)
Ambient temperature	-40°C ~ +105°C (no condensation)	
Unit weight	Approx.28.0g	

#### Coil Data (at 20°C)

Nominal voltage (VDC)	Nominal operating current 10% ( mA)	Coil resistance 10% ( Ω)	Max. allowable voltage	Pick-up voltage (Max.)	Drop-out voltage (Min.)	Nominal operating power
5	180.00	27	110 % of nominal voltage	75 % of nominal voltage	5 % of nominal voltage	0.90W
6	150.00	40				
9	100.00	90				
12	75.00	160				
15	60.00	250				
18	50.00	360				
24	37.50	640				
48	18.75	2,560				
110	8.21	13,400				

### Safety Approval Ratings

(Note:More detail of approval ratings,please refer to the safety certification)

Approval	CQC	TUV	UL/CUL	VDE
File No.	CQC02001002109	R50143450	E190598	40036707
Approved ratings	Form A : 30A 250VAC	Form A : 30A 240VAC Making: 80A 250VAC(300ms) Breaking:20A 250VAC	Form A: 40A 277VAC, Resistive 30A 240VAC, Resistive 15A 240VAC 1-1/2HP 240VAC 3/4 HP 120VAC TV-8 120VAC 30A 240VAC, General Use Pilot duty: 470 VA, 240VAC Electronic Ballast: 10A 277VAC /120VAC	30A 250VAC,NO 20A 250VAC,CO(test NO) 10A 250VAC,CO(test NC)
	Form B : 15A 250VAC Form C : 20A/10A 250VAC	Form B : 15A 240VAC Form C : 20A/10A 240VAC	Form B: 30A 120VAC, General Use 10A 240VAC, Resistive 10A 240VAC, General Use Pilot duty: 275VA, 240VAC Electronic Ballast: 5A, 277VAC/120VAC Form C: N.O. N.C. 20A 240VAC, Resistive 10A 240VAC, Resistive 1-1/2HP 240VAC 3/4HP 125VAC TV-8 120VAC 20A 240VAC, General Use Pilot Duty: 470VA 240VAC Electronic Ballast: 10A 277VAC/120VAC	

- (1) The above-mentioned unspecified temperature ratings, means that the ambient temperature is room temperature.
- (2) Only some typical ratings are listed above. Each rating's test condition is different, so the electrical endurance will be different. If more details are required, please contact us.
- (3) For sealed type testing, please open the ventilation hole of case before test.

### Ordering Information

Nomenclature											
SLI	- S	- 1	12	D	M	K	1	- G	- P	- F -XX	Special Parameter : Nil-Standard type, Letter or number-Special requirement
Insulation System : Nil-Standard, B-Class B, F-Class F											
COM Flat quick-connect terminals: Nil- Yoke and flat quick-connect terminal is one part; P-Yoke rivet flat quick-connect terminal only for SLI-K											
Parameter sign : Nil-Standard,G-High contact load,Double-layer spring,Ø5.0 Contact											
Contact Material : Nil-AgSnO <sub>2</sub> , 1-AgCdO											
Terminal position: Nil-COM terminal and NC/NO terminal on the same side K-COM terminal and NC/NO terminal on the opposite side											
Contact Form : Nil-Form C, B-Form B, M-Form A											
Coil Power : D-0.90W											
Coil Voltage (VDC) : 05, 06, 09, 12, 15, 18, 24, 48, 110											
Number of Poles : 1-1 Pole											
Protective Construction : S-Flux proofed,SH-sealed type washable											
Type Designation : SLI											

Outline Dimensions, Wiring Diagram, P.C. Board Layout (unit : mm)

SLI

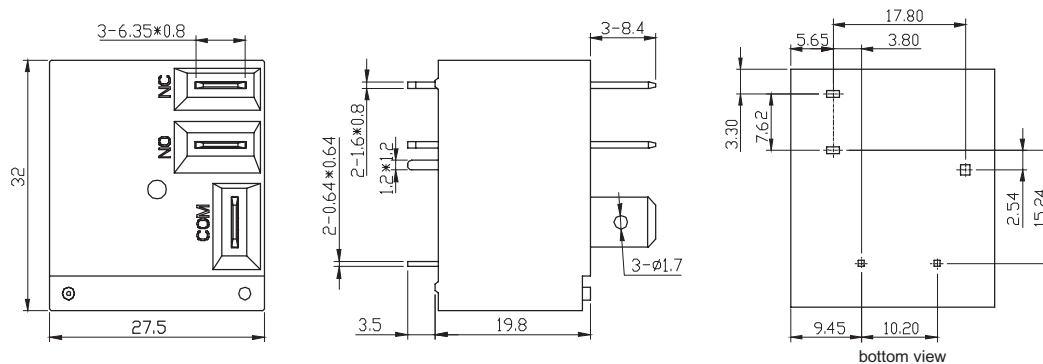

SLI-K

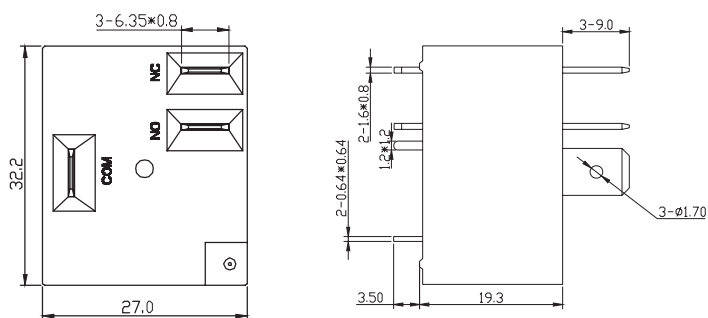

Unless otherwise specified :  
 If dimension < 1mm, tolerance : 0.2 mm;  
 If dimension 1~5mm, tolerance : 0.3 mm;  
 If dimension > 5mm, tolerance : 0.4 mm.  
 Note : 1. Extended terminal dimension is dimension before soldering.  
 2. Tolerance of P.C.B. layout : 0.1 mm.

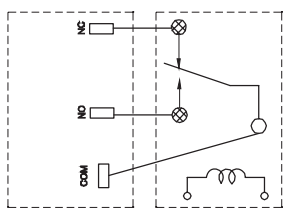

(top view) (bottom view)

1c

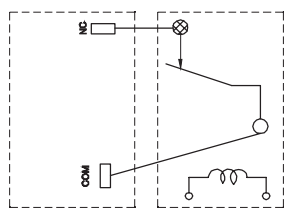

(top view) (bottom view)

1b

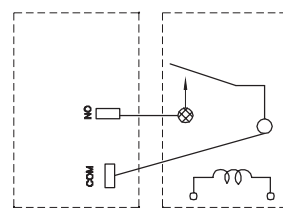

(top view) (bottom view)

1a

SLI Wiring Diagram

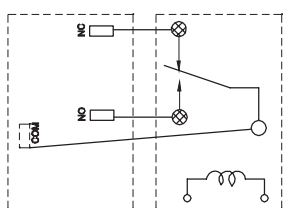

(top view) (bottom view)

1c

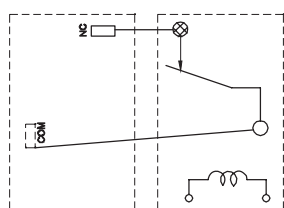

(top view) (bottom view)

1b

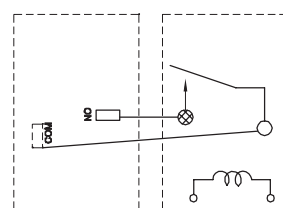

(top view) (bottom view)

1a

SLI-K Wiring Diagram

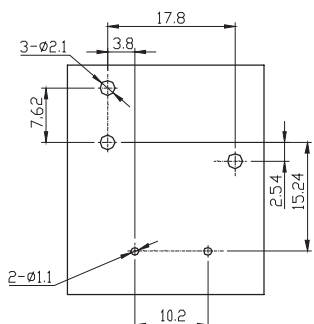

1c

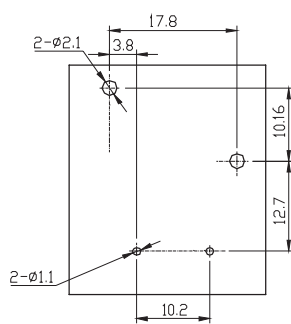

1b

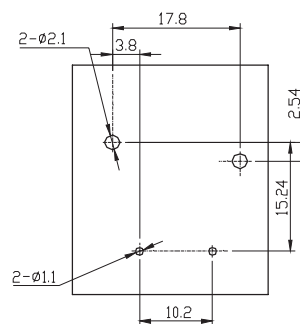

1a

P.C.B. Layout(bottom view)

## Typical Applications

- Car
- Air conditioner
- Heater and ventilation equipment
- Home appliances

## Characteristic Curves

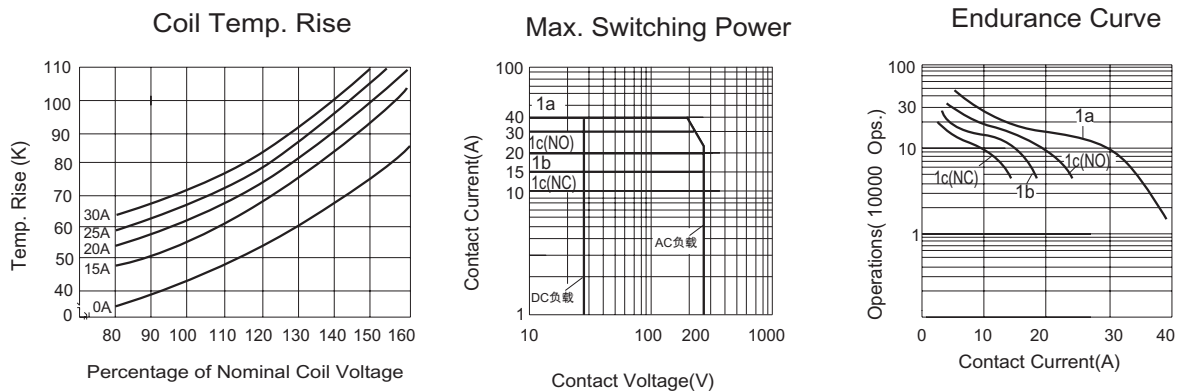

Note: If you choose the sealed type, before using, please remove the convex platform at the top of the case to ensure the normal performance of the relay after the completion of a PCB operations. they are as shown in the following diagram:

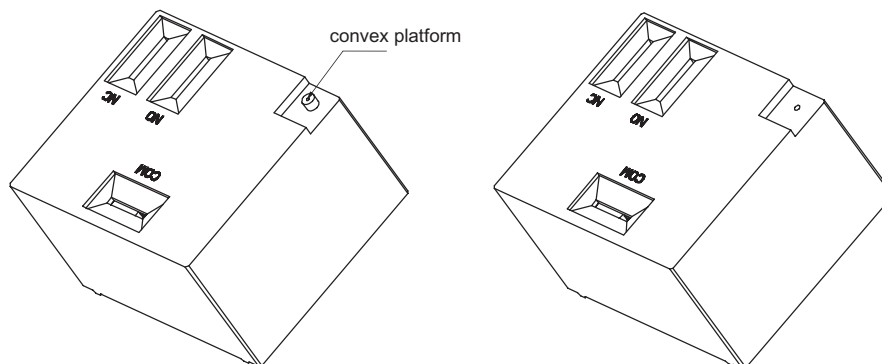

SLI-K

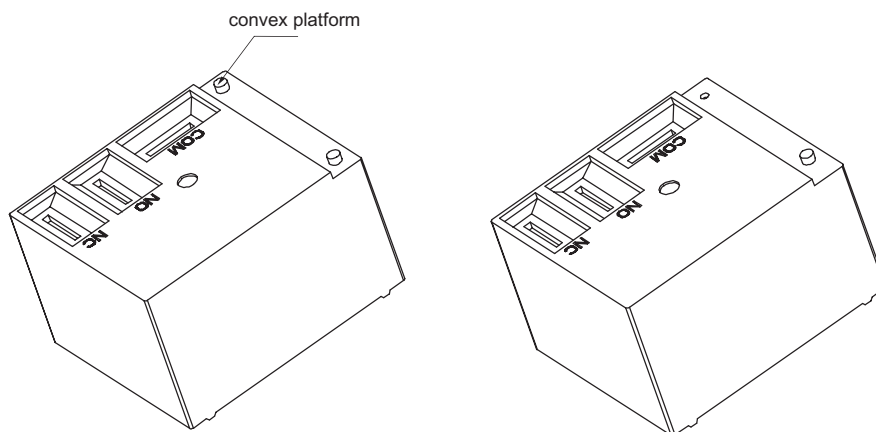

with convex platform

without convex platform

### Disclaimer:

This datasheet is the customers' reference. All the specification are subject to change without notice.

We could not evaluate all the performance and all the parameters for every possible application. Thus the user should in a right position to choose the suitable product for their own application. For sealed relays after installation and cleaning, please open the vent hole on the case before use. If there is any query, please contact Sanyou for the technical service. However it is the user's responsibility to determine which product should be used only.